

A SAFER WAY TO REACH NEW HEIGHTS

UTS 700 FOLDOUT

Instruction Manual

Mobile Access Tower



Instruction Manual

This Assembly Guide is intended to provide you with step-by-step instructions on how to erect your Mobile Access Tower (MAT) with ease and safety, using the 3T (through the trap) method.

You should read and understand all notes and diagrams, including the parts list for each height, before commencing assembly. Personnel should be qualified or competent to erect this tower. Please consult the PASMA's code of practice for full information on the use of Mobile Access Towers.

Remember to do a risk assessment of the area where the tower is to be used before commencing erection.

This instruction manual shall be available on the location of use of the mobile access and working tower.

This mobile access and working tower shall only be used according to this manual without any modification.

Manufactured to: BSEN1004-1:2020 CLASS 3 8/8 XXXD



KM 617169



HEALTH AND SAFETY WARNINGS

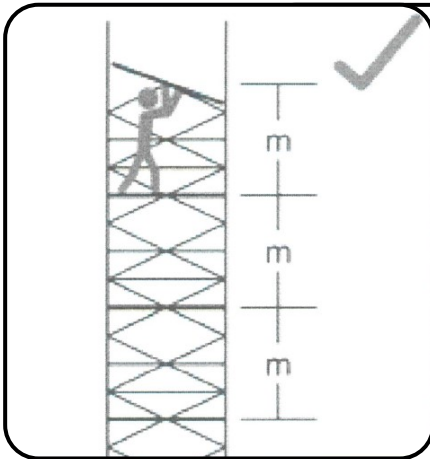

Maximum height between platforms of 2.2m

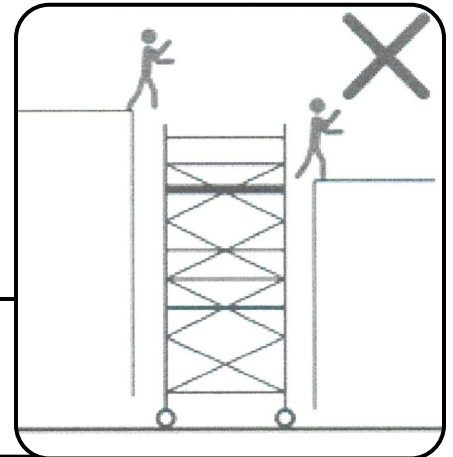

Do not use the tower as a form of access or exit

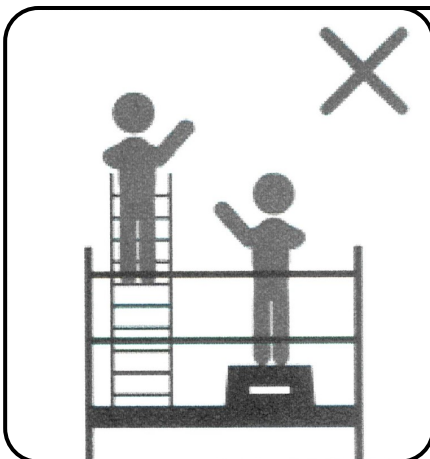

Do not use ladders, boxes or any other objects to gain additional

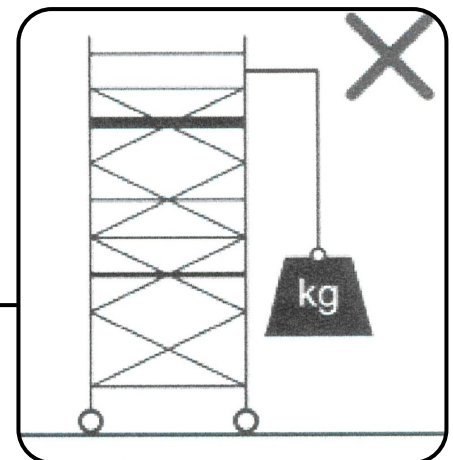

Do not lift heavy objects from the tower

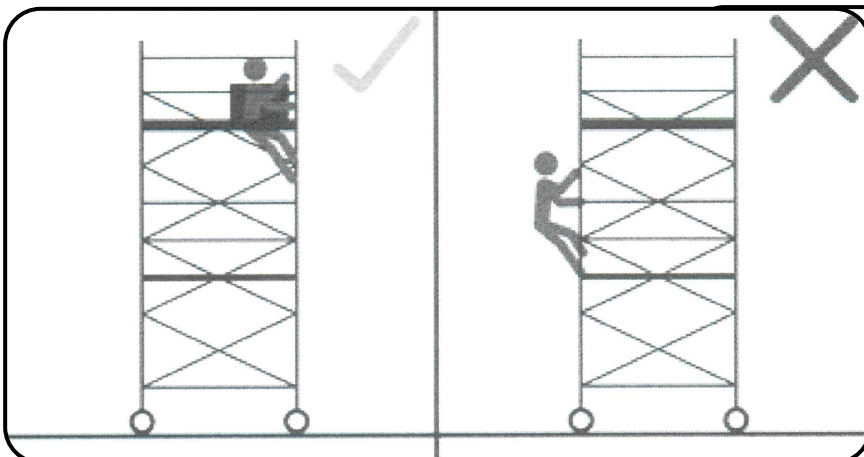

Do not climb outside of the tower, only climb up inside the tower.

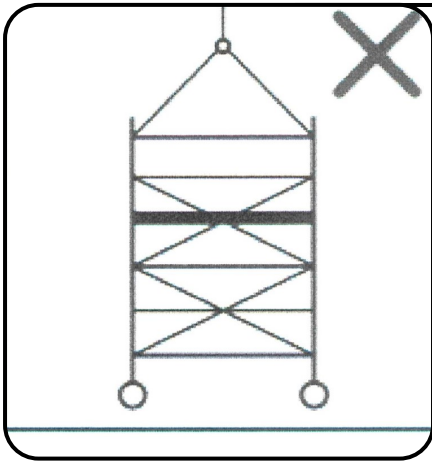

Do not suspend or lift the tower

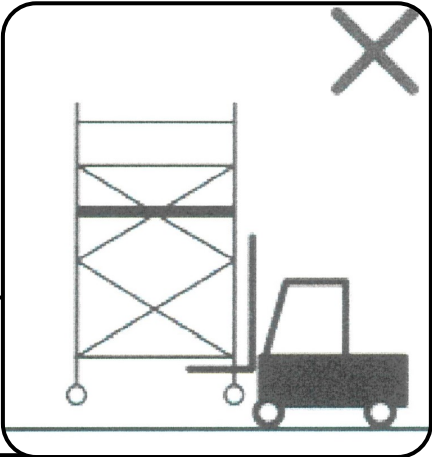

Do not lift the tower with mechanical equipment

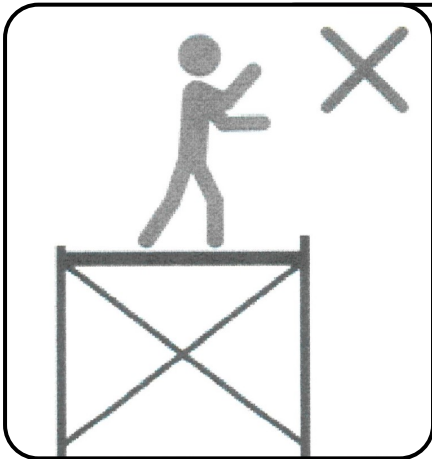

Do not stand up on an unguarded platform

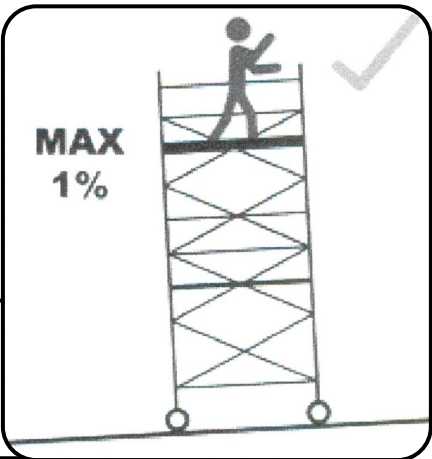

Maximum inclination for working = 1%

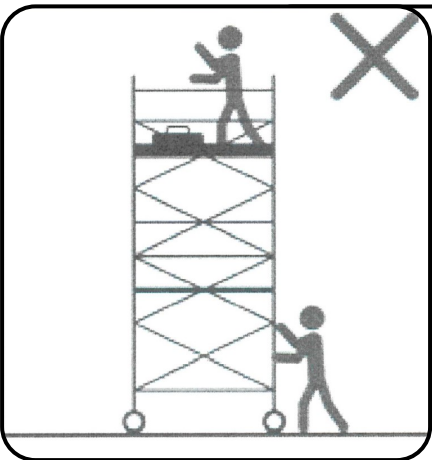

Do not move the tower with material or people on it

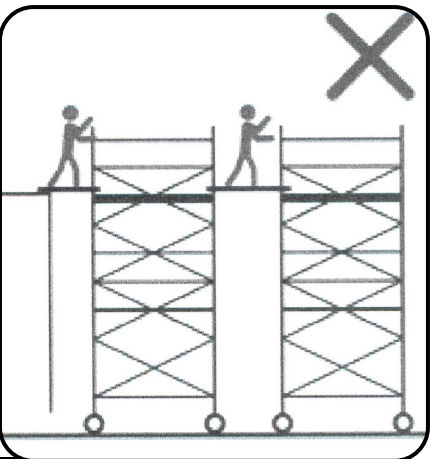

Do not bridge between towers or other structures

UTS 700 FOLDOUT

Instruction Manual

Mobile Access Tower

Contents	Page
Description	5
Safety Notes & Fittings	5
Inspection Care and Maintenance	7
Components and Weights	10
Assembly	11
Dismantling	20
Configurations and Weights	21
Risk Assessment Form	22

Description, Safety Notes & Fittings

Description

The UTS 700 FOLDOUT tower is manufactured to BSEN1004-1:2020 CLASS 3 8/8 XXXD and KITEMARKED. The KITE MARK is the universal symbol that reassures the user that the product is certified to BSI stated standards.

- Instructions for erection and use to be followed carefully.
- A risk assessment should always be carried out before erecting your MAT (Mobile Access Tower).
- You will find a standard risk assessment form at the back of this instruction manual.
- The UTS 700 FOLDOUT has a maximum working platform height of 6.05 meters indoors or outdoors.
- The maximum permissible load on the UTS 700 FOLDOUT tower is 750kgs and evenly distributed on each platform is 275kgs. This must not be exceeded over the working height platform, not including rest platforms.
- Maximum of 1 working platform per tower.
- Maximum of 2 people per working platform.
- Damaged or incorrect components shall not be used.

Safety Notes

ERECTION & DISMANTLING - THE 3T(through the trap) METHOD

Towers should be erected following a safe method of work, there are two approved methods recommended by 'Prefabricated Access Suppliers & Manufacturers Association' (PASMA) in co-operation with the Health and Safety Executive (HSE) & the "working at height regulations 2005"

The method used for erecting and dismantling the UTS 700 FOLDOUT tower is the 3T METHOD (through the trap).

This method ensures the operators erecting the tower position themselves in the trapdoor of the platform to add or remove horizontal guardrail braces for the level above the platform.

NEVER STAND ON AN UNGUARDED PLATFORM.

Before assembly or erection of this Mobile Access Tower (MAT) please ensure that:

- A risk assessment has been done and all safety equipment is on site.
- The ground conditions will take the working loads of MAT as specified.
- Always check that the MAT is vertical, (Level, slope, uneven ground etc.) if levelling is required make sure you adjust legs, in line with instructions (use spirit level).
- Beware of (overhead) obstructions – live wires, electrical apparatus or moving parts of machinery or other.
- Wind conditions are within limits as specified. (Refer to page 6)
- Do not use boxes, ladders, or other devices on the platform to gain additional height.
- If in doubt DO NOT ERECT.
- Check that all components are on site and that they are in good working order before use (refer to the components and quantities shown at each stage). Auxiliary equipment and safety equipment. (ropes, etc)
- All platforms MUST have horizontal guardrails fitted.
- The tower should always be accessed from the inside using the rungs of the end frames.
- Never climb up the outside.
- Do not use the guardrail braces as a rung or step.
- It is recommended that 2 persons erect this tower.
- The assembled tower should not be used as a means to enter or exit other structures, e.g. as a stair tower.
- Beware of horizontal forces (e.g., when using power tools on an adjacent structure), which could generate instability or overturning of the tower.
- Maximum distance between platforms is 2.25m, maximum distance to the first platform is 3.4m.
- Maximum horizontal force 20kgs.
- Mobile access and working towers are not designed to be sheeted
- The tower height used should be appropriate for the working height, e.g. within 2 meters above the platform

- User training courses cannot be a substitute for instruction manuals but only complement them.
- Only the original UTS components specified in the manual shall be used.
- Mobile access and working towers designed in accordance with BS EN 1004-1:2020 are not anchor points for personal fall arrest equipment.
- Working is only permitted on a platform with a complete side protection including guardrails and toe boards.
- Mobile access and working towers are not designed to be used as edge protection.

STABILISERS & BALLAST

Stabilisers or outriggers and ballast shall always be fitted when specified. When using the MAT externally stabilisers must be fitted. Should ballast be required, a platform should be positioned on the lowest rung and the weights should be firmly attached to it and evenly distributed. For advice on ballast contact your supplier.

LIFTING OF EQUIPMENT

Tools and other equipment should be hauled up by a person on the platform using rope or similar, through the trapdoor of the platform or within the tower footprint.

Please see footprint guide on page 16.

Safe working loads of platform and tower not to be exceeded.

MOVING THE TOWER AND LEAVING IT UNATTENDED

- Adjust the stabilisers to provide ground clearance.
- Unlock the castor wheels.
- Move with manual force only, and only from the base.
- Beware of (overhead) obstructions – live wires, hanging apparatus or other objects.
- Do not move with people or material on the tower.
- Do not move the assembled MAT if wind speeds exceed a moderate breeze. Relock the castors and readjust the stabilisers once in the new position.
- When moving the tower over uneven or sloping ground remove all tools.
- Do not move the assembled tower if over 4 meters high.
- Recheck that the MAT is vertical or needs readjustment of legs before ascending. (Using spirit level)
- Mobile access and working towers shall only be moved on a flat and solid ground without obstacles and not on a slope of more than 10mm/1m
- It is recommended that towers should be tied to a solid structure, when left unattended.

TIES

When ties are required, they should be in accordance with table 17 of BS 5973:1990 and table 24 of BS 5975:1982.

Always tie to a solid structure.

The tie frequency should be at 4 meter intervals or less vertically.

LIFTING OF INDIVIDUAL TOWER COMPONENTS

Raising and lowering components, tools and/or materials by rope should be conducted within the tower base (i.e. within the

CHECK LIST, INSPECTION CARE AND MAINTENANCE FOR MOBILE ACCESS TOWERS

- All components should be inspected before use to ensure that they are not damaged or broken, particularly the welds.
- ANY damage to ANY part particularly tubular members, castors, platform decking MUST be replaced.
- Adjustable leg threads should be cleaned and lightly oiled.
- All locking claws should be cleaned, and the locking mechanism checked for operation.
- When storing your MAT, please ensure that all components are neatly stored and not left lying around where they could be stood on or damaged.
- When transporting the MAT always tie the components down so that they do not move around and get damaged.
- Should the tower be left unattended it should be tied to a suitable structure and on reuse ALWAYS check that the tower is vertical and safe before ascending correct and complete structure.
- The MAT is not designed to be lifted or suspended as a complete structure.
- Always keep this instruction manual safe.
- Broken, damaged or incorrect components must never be used. The equipment shall be quarantined and assessed for replacement repair or destruction.

WIND EFFECTS

- Beware of high, gusty, or moderate breeze conditions in exposed areas. It is recommended that in wind speeds over a Moderate Breeze (see Beaufort Scale below) that work on the tower is stopped and reassessed. If the wind becomes a Strong Breeze, (see Beaufort Scale below) the tower should be tied to a rigid structure. If the wind is likely to reach Gale Force (see Beaufort Scale below) or over, work should be stopped, and the tower should be dismantled.

Wind	Beaufort Scale 10 Meters above ground	Force	Speed in m.p.h.	Speed in knots
Moderate Breeze	Raises dust and loose paper, small branches move.	4	13–18	11–16
Strong Breeze	Large branches in motion, telegraph wires whistle.	6	25–31	22–27
Gale Force	Walking is difficult, twigs break off trees.	8	39–46	34–40

LOCKING CASTORS

Castor wheels should be pointed outwards at approximately 45 degrees and locks engaged as shown opposite.

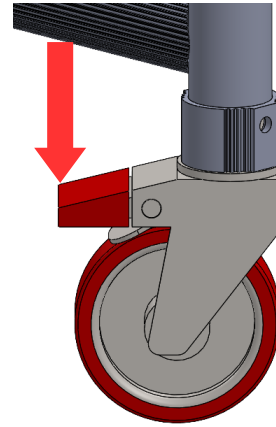

CORRECT FITTING OF HORIZONTAL BRACING

THE CORRECT FITTING OF HORIZONTAL BRACING IS IMPORTANT.

The diagrams opposite illustrate the CORRECT brace positions.

REMEMBER: Always fit braces DOWNWARD or from the inside facing OUTWARD – BUT NEVER INWARD

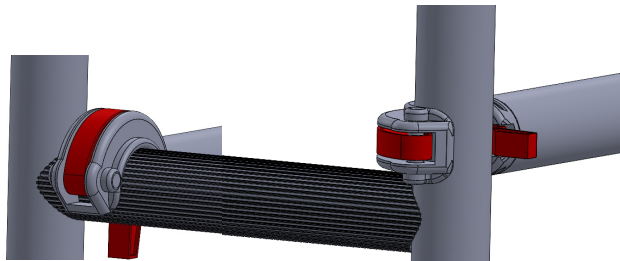

FOLDOUT LOCKING BASE

Push the central hinged frame outwards until flat.

Keep going until the top hinge locks into position.

Unfold the two end frames.

Lock the castor brakes.

Un-Locked

Collapsed

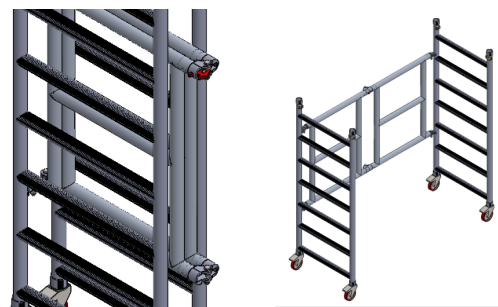

BRACE CLAMP LOCKING

Ensure that the brace clamp is locked as shown.

Always make sure the brace is not clamped too close to the weld as

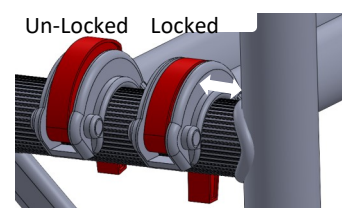

FITTING STABILISERS

To attach stabilisers clamps, undo palm wheel all the way, fit one side of clamp to vertical frame, then rotate second side of clamp to fit vertical frame and tighten palm wheel.

Attach a stabilisers in configurations as shown on pg19 for maximum stability in

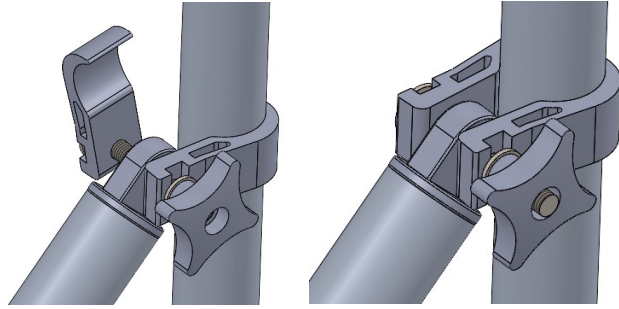

FITTING TOE-BOARDS

1 piece folding toe board

Unfold out over platform, hook bottom edges over sides of platform.

Ensure short ends of toe boards have hooked over both ends of the platform, hook bottom edge down between platform hook and frame.

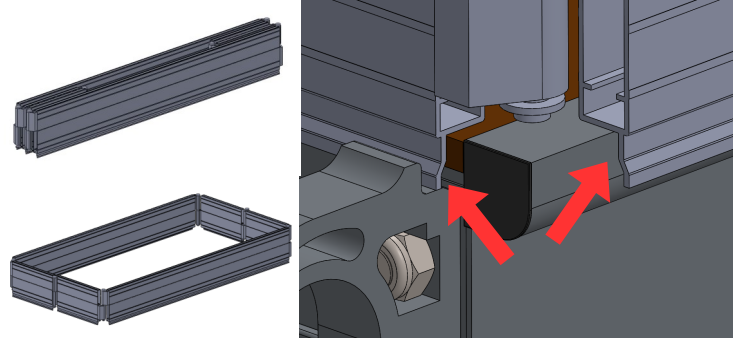

LOCKING CLIPS

Fit the locking clips as shown in the diagram opposite.

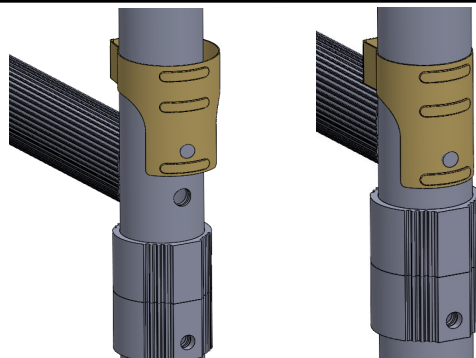

Identifying Components and Their Weights

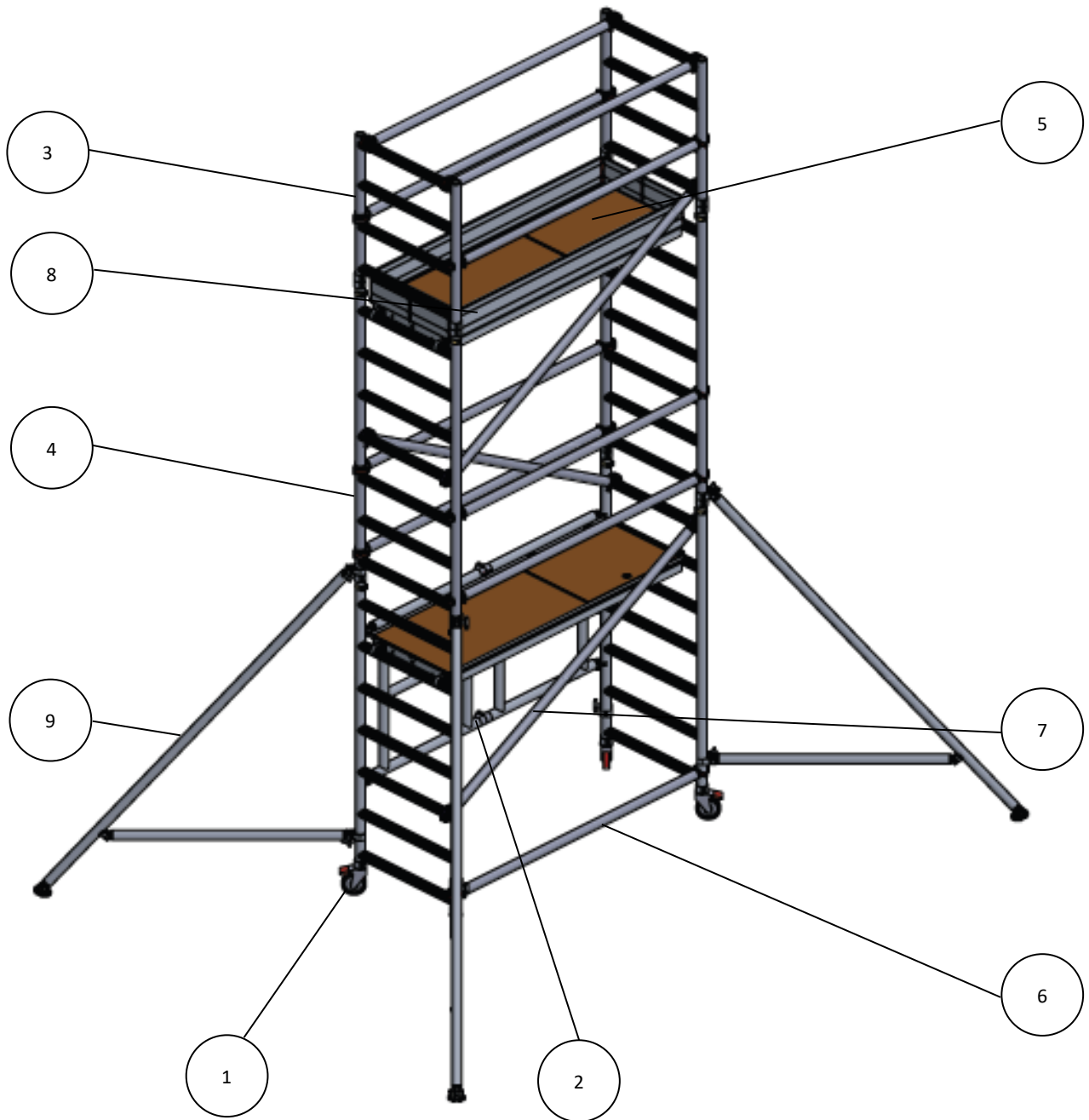

Tower Components and Approx. Weights

Item	Description	Weight (Kg)	Item	Description	Weight (Kg)
1	125mm Locking Caster	3.4	6	1.8m Horizontal Brace	1.92
2	1.8m Folding Frame	3	7	2.1m Diagonal Brace	2.1
3	1m 4 Rung Frame	5.6	8	Complete Toe Board Set	12
4	1.75m 7 Rung Frame	9.8	9	S1 Stabiliser	7
5	1.8m Trapdoor Platform	15			

Assembly Procedure

UTS recommends that a minimum of two people is required for the assembly of the UTS 700 FOLDOUT tower. Only climb the tower from the inside using the end rungs.

Platform Heights in Meters	Frame at top
0.8, 2.5, 4.3, 6.05	7 Rung
1.8, 3.5, 5.3	4 Rung

1. Insert castors or base plates into the bottom of end frames
Lock all castor wheels

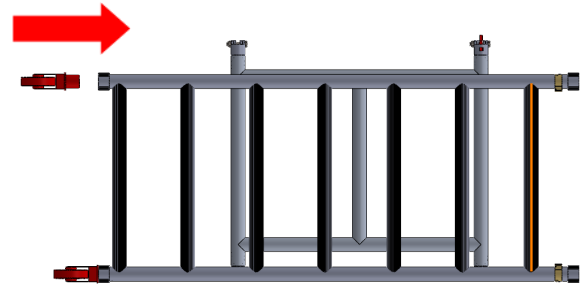

2. Stand the base unit up and push the central hinged frame outwards until flat. (Ref page 7)
Lock the castor brakes.

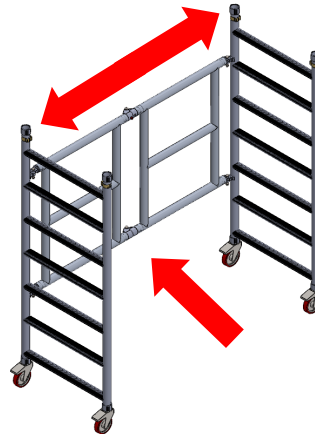

3. Position the frame as shown. Use a horizontal (red) brace to square the frame.
Use position A for platform height 0.8m
Use position B for all other platform heights.
Refer to page 7 for fitting instructions.
Check tower is vertical (Using spirit level)

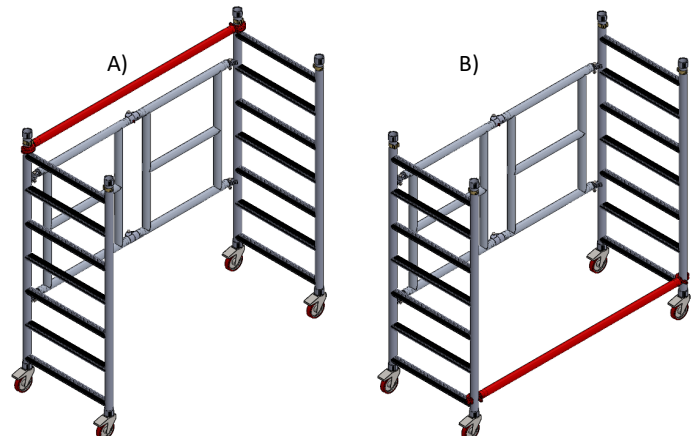

PLEASE TAKE NOTE

Never place the platform on the guardrail frame

Always climb from the inside of the frame – never the outside.

When working on the platform never overreach

0.8m Configuration Assembly Instructions.

1-3. Start with steps 1—3 on page 9

Fit platform to 3rd rung of tower, ensure wind locks are engaged.

From a seated position within the tower fit the other 2 guard rails just above the 5th and 7th rungs.

4. Do not stand on platform until all guardrails are in place and secure.

If your risk assessment shows it necessary, fit a set of toe boards to the platform. Check there are no

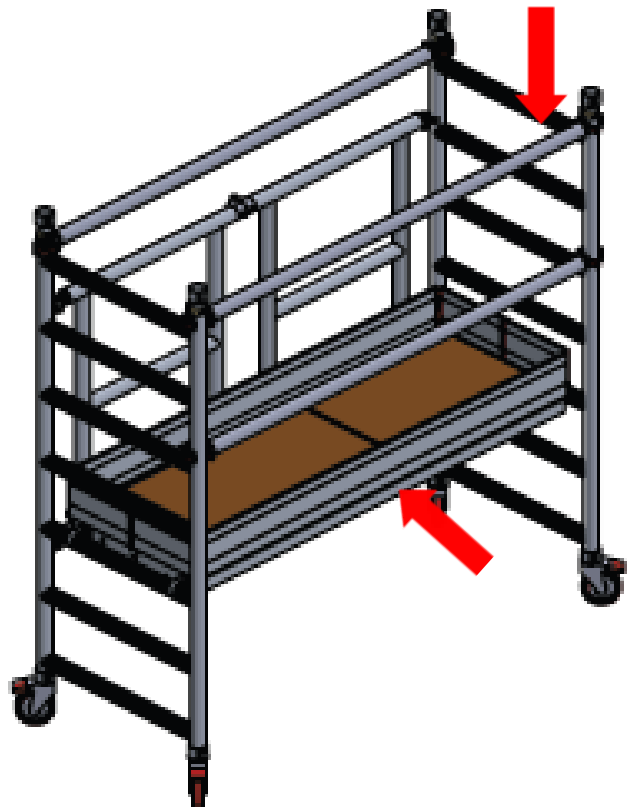
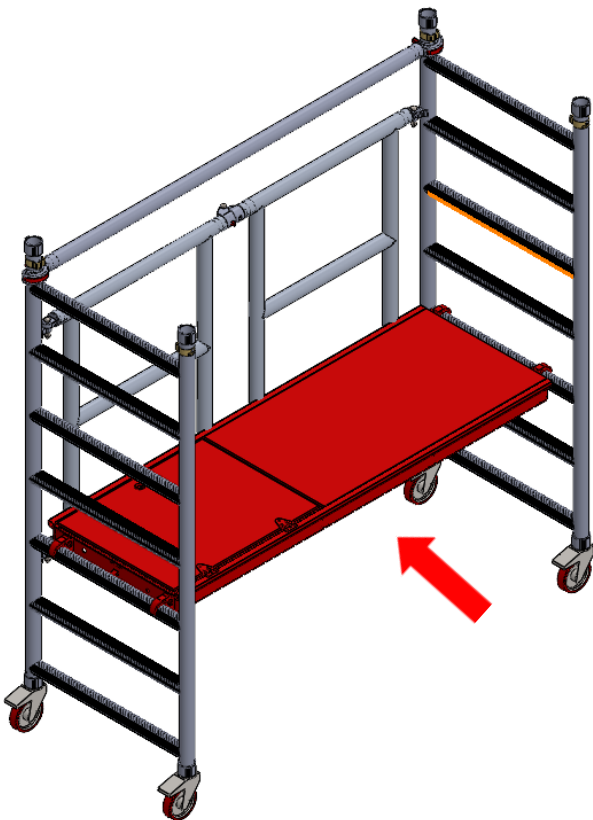

1.8m Configuration Assembly Instructions.

1-3. Start with steps 1—3 on page 9

Fit 4 rung sides to each end of base, ensure clips are engaged (ref page 6).

4. Fit a trap door platform to top rung of the base frame side, engage the wind locks.

Connect a diagonal brace (blue) between the 3rd rung on one end and the 7th on the other end.

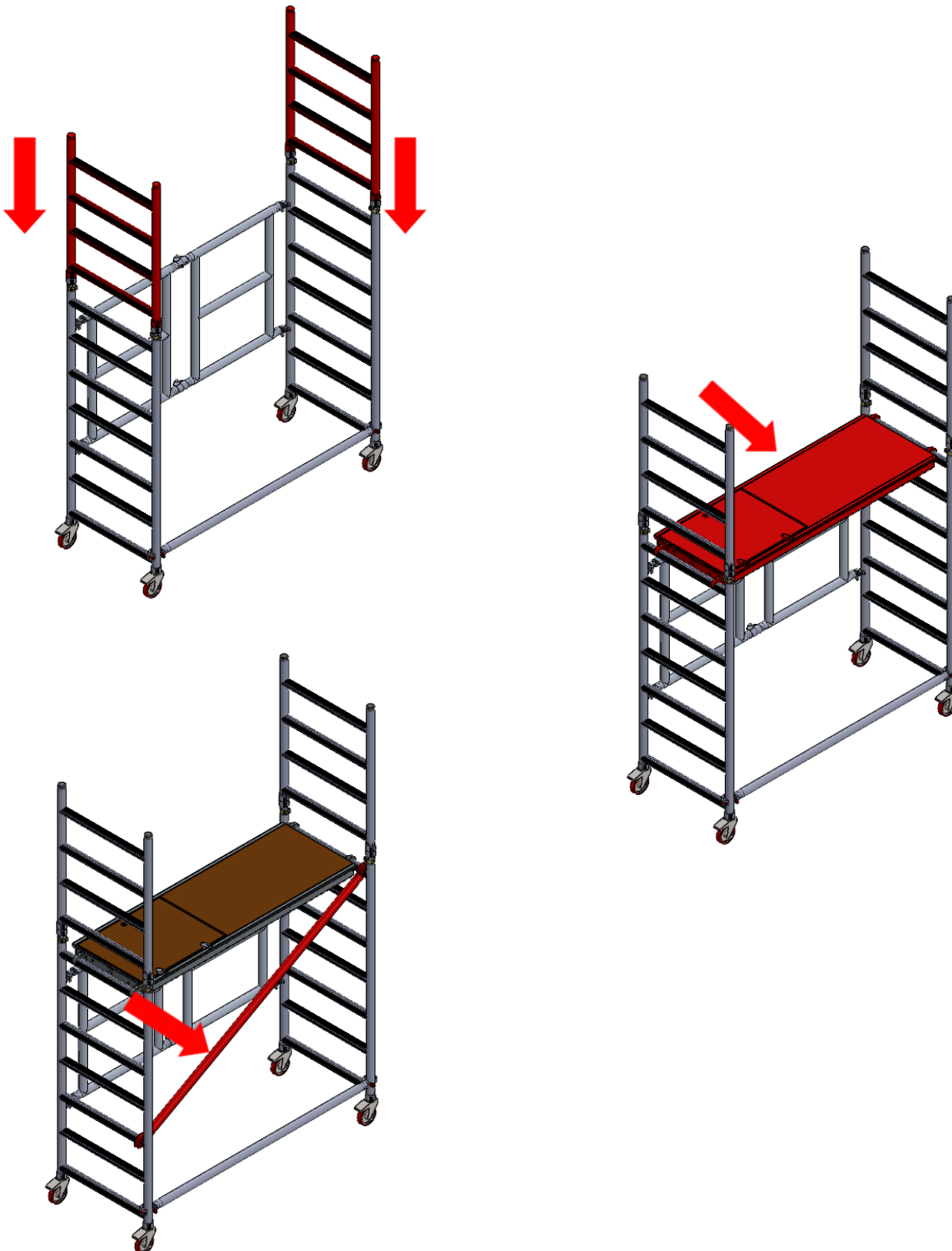

Attach stabilisers, ensure connected and tightened.

5.

Climb the tower on the inside using the rungs of the end frames. From a protected position within the trapdoor, fit 4 horizontal braces as guardrails, 2 and 4 rungs above the platform (the 9th and 11th rungs of the tower), on both sides of the tower.

Fit toe boards to the working platform. (see instructions on page 8)

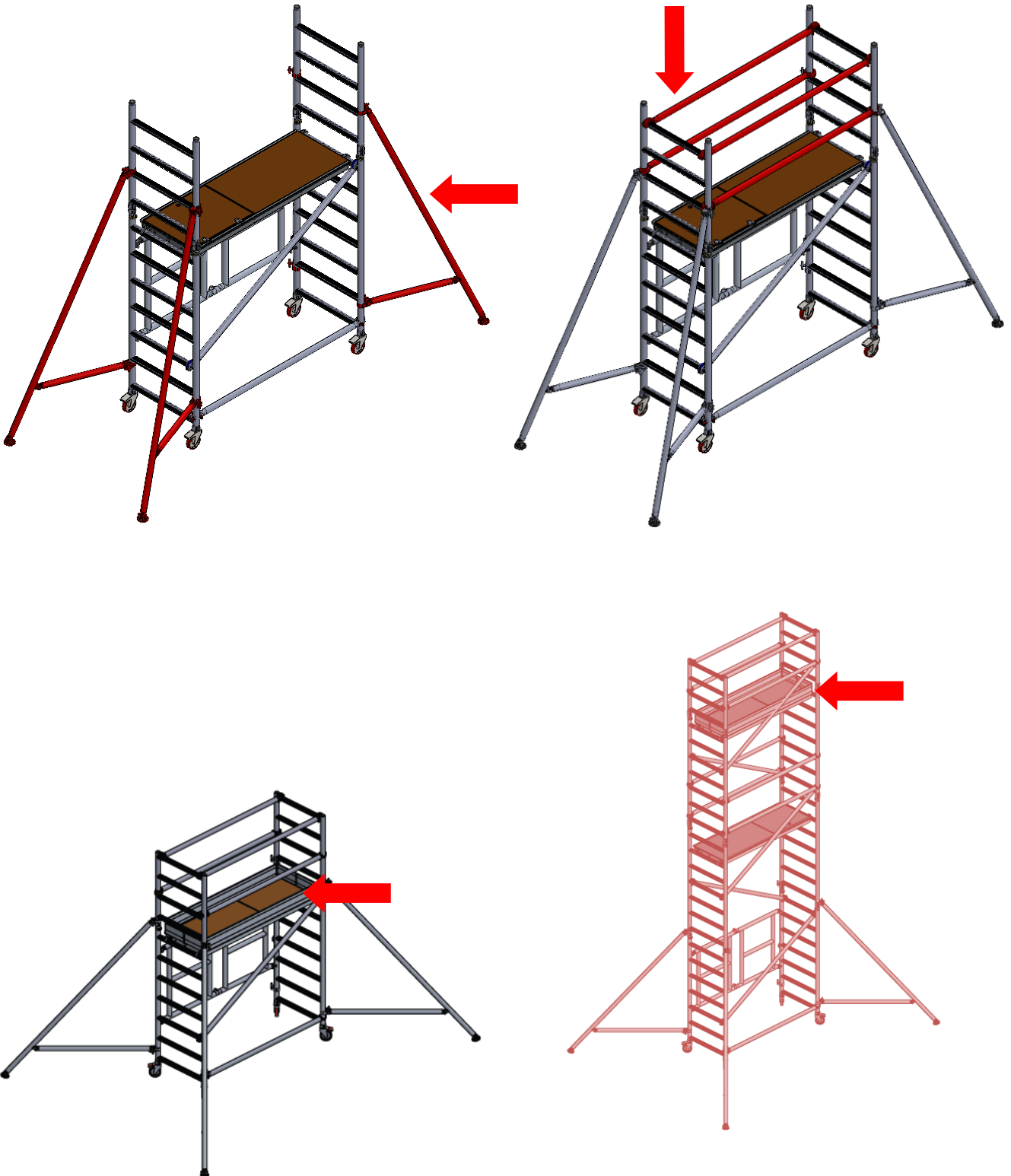

3.5/ 5.3m Configuration Assembly Instructions.

1-3. Start with steps 1—3 on page 9

Add a platform on the 2nd rung, lock wind locks, and a diagonal brace (blue) between the 2nd and 6th rungs.

4. Insert a 7 rung end ether end of the base, then add another platform to the 10th rung, lock wind locks. Attach the stabilisers to the corners of the tower.

Fit an additional diagonal brace from 6th to 10th rung. Then from a seated position within the trap of the platform fit 4 horizontal braces (red) as guardrails on the 12th and 14th rungs.

Now fit the 4 rung ends to each end of the tower.

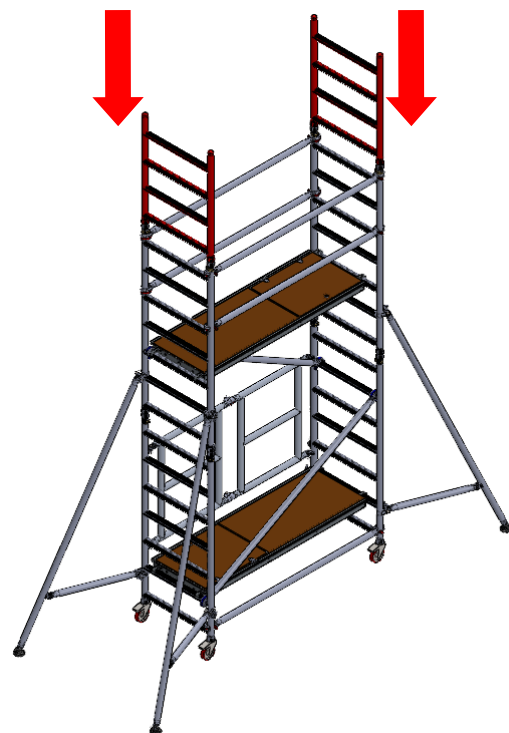
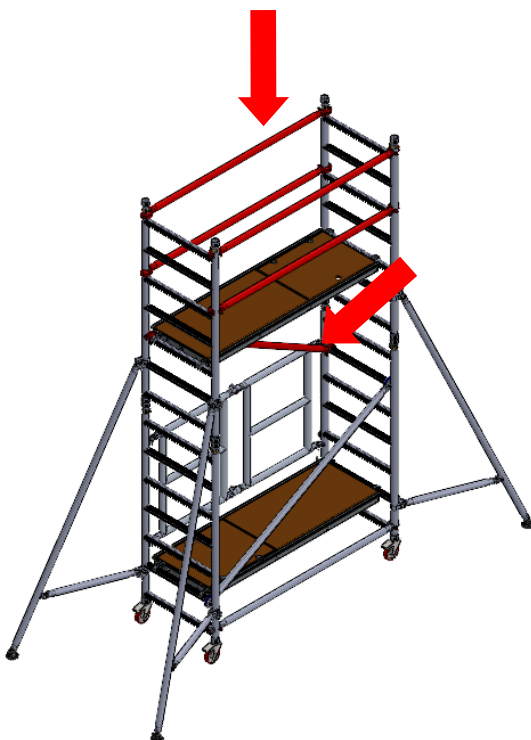
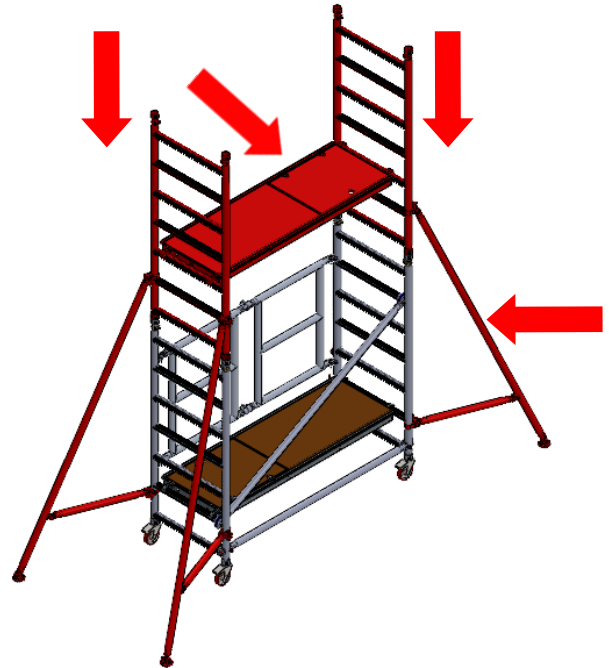
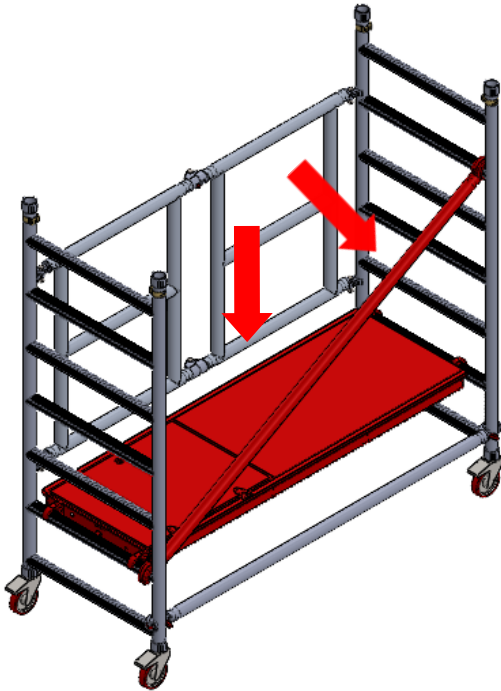

Dismantle platforms and guard rails leaving ends and diagonals in place and reposition bottom platforms to 6th rung with guardrails on the 8th and 10th rungs.

Fit second platform to 14th rung with guardrails at 16th and 18th rungs.

5.

Fit final 2 diagonals following pattern described in previous steps.

Fit a set of toe boards to the platform. Check there are no gaps through which any material could fall and the trapdoor opens correctly

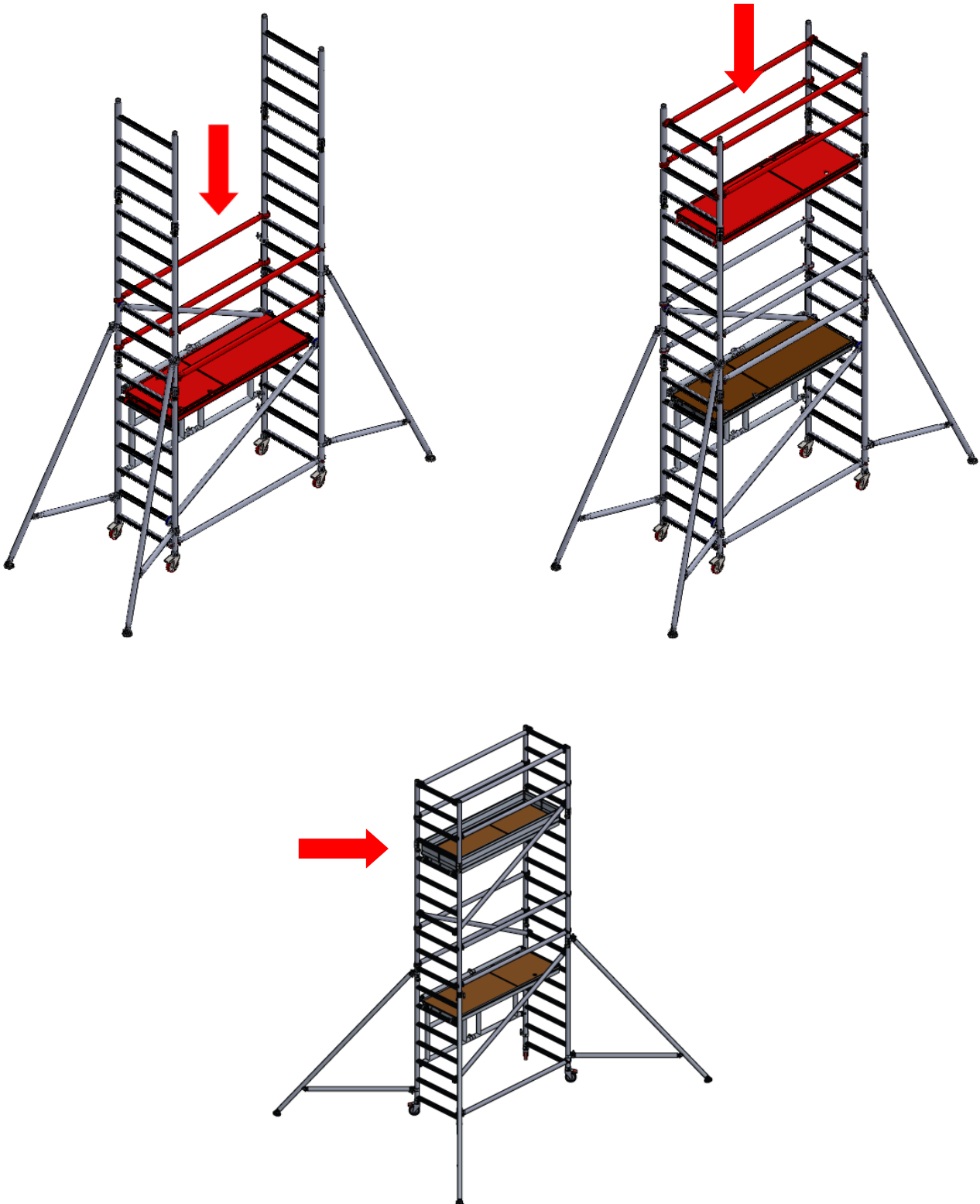

If building to 5.3m platform height:

Use the same method but use a pair of 1.75m frames instead of the 4 rung frames.

Move the top deck and handrails down 1 rung.

6.

Add the 4 rung frames to the top of the 1.75m 7 rung frames.

Continue the zig zag diagonal pattern.

Remove and refit the lowest platform and hand rail braces to the 21st rung of the tower with the handrails 2 and 4 rungs above the platform.

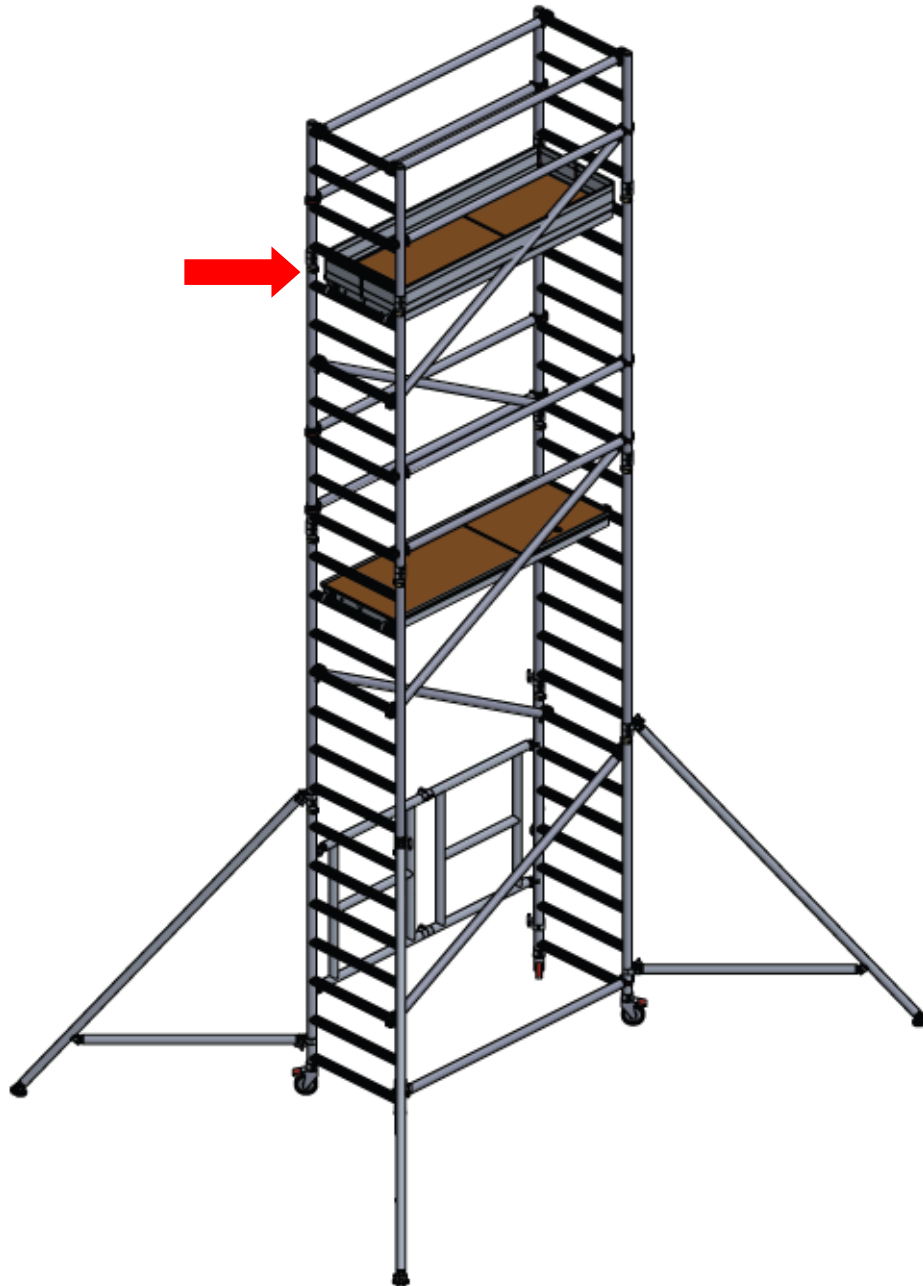

2.5/4.3/6.05m Configuration Assembly Instructions.

1-3. Start with steps 1—3 on page 9

Add a platform on the 2nd rung, lock wind locks, and a diagonal brace (blue) between the 2nd and 6th rungs. Insert a 7 rung end ether end of the base, then add another platform to the 10th rung, lock wind locks.

4.

Attach the stabilisers to the corners of the tower.

Fit an additional diagonal brace from 6th to 10th rung. Then from a seated position within the trap of the platform fit 4 horizontal braces (red) as guardrails on the 12th and 14th rungs.

Fit another diagonal in the pattern , If completing at 2.5 add toe board , if not proceed to next step.

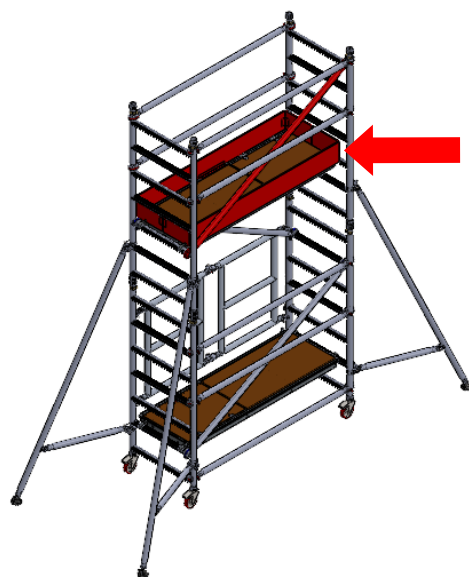
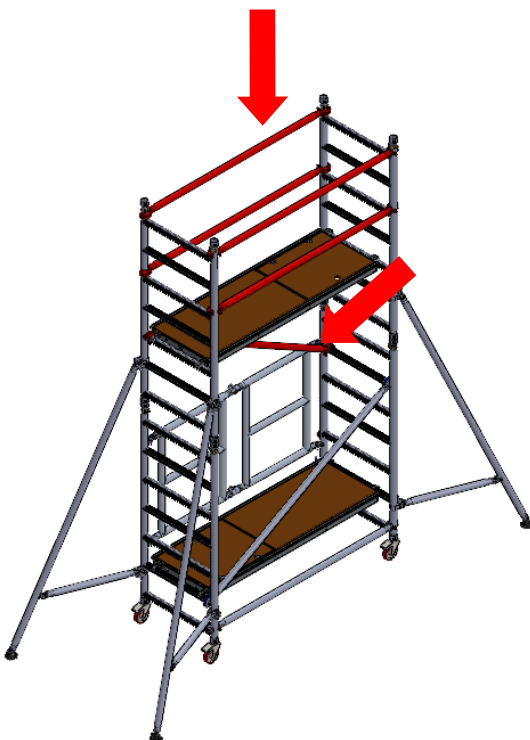
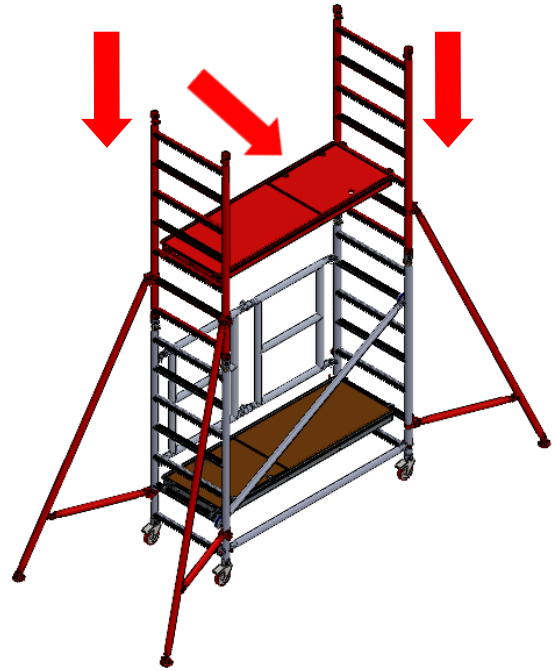
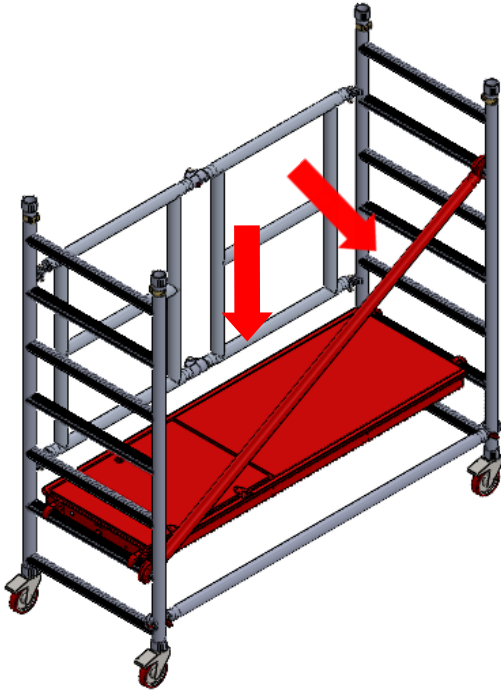

For 4.3/6.05m configurations continue to fit additional pairs of 7 rung lift frames, diagonal braces, horizontal guardrails and trapdoor decks.

5.

DO NOT CLIMB ON THE PLATFORM UNTIL IT IS FULLY GUARD RAILED

Fit a set of toe boards to the platform. Check there are no gaps through which any material could fall and the trapdoor opens correctly

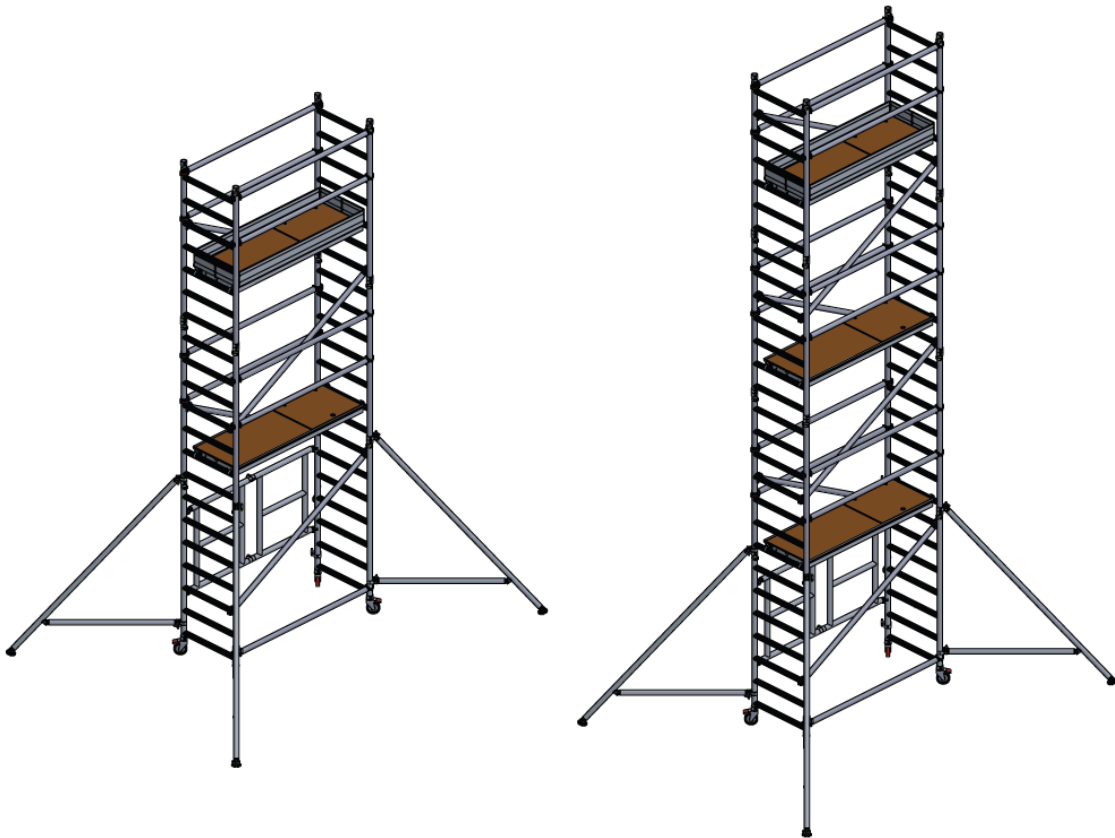

Dismantling

The dismantling procedure should follow the assembly steps in reverse order, take particular attention about the removal of guardrails and platforms.

You should ensure that you are standing in a safe position and always protected by guardrails NEVER remove diagonal braces or stabilisers prematurely.

After removing the toe-boards the operator disengages the horizontal guardrail brace clamps furthest from the trap door, horizontal guardrail braces are then removed with the operator positioned through the trap door before descending to the lower level, from where the upper platform and extensions/ guardrail frames can be removed.

NOTES:

DO NOT OVER-REACH and NEVER DROP COMPONENTS when dismantling always lower them to the

STABILISERS

Attach one stabiliser to each corner of tower at approx. 45 degrees. The bottom clamp should be fitted as low as possible, refer to the diagram opposite. Ensure that all four rubber feet are in contact with the ground and that the clamps are secured. Position stabilisers as shown in the diagrams.

When moving the tower lift each telescopic leg just clear of the ground, unlock castors ensuring area is firm and clear of all obstructions both on the ground and above.

After moving check all castors are firmly on the ground and locked, and that the tower is vertical. Re-position stabilisers as above.

When using tower near a wall or in a corner, the stabiliser layout needs to be adjusted to accommodate.

As shown in the diagram if against a wall 2 stabilisers should be made parallel to the wall and the others should remain at 45°.

If being used in a corner, the closed corner stabiliser can be removed and the 2 near walls should be made parallel with the

STABILISERS—S1

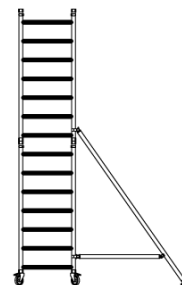
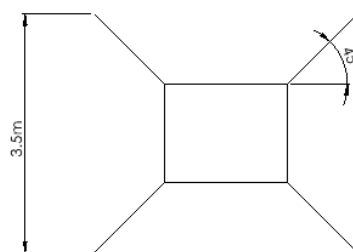

Static Stabiliser maximum platform height of 4.2m

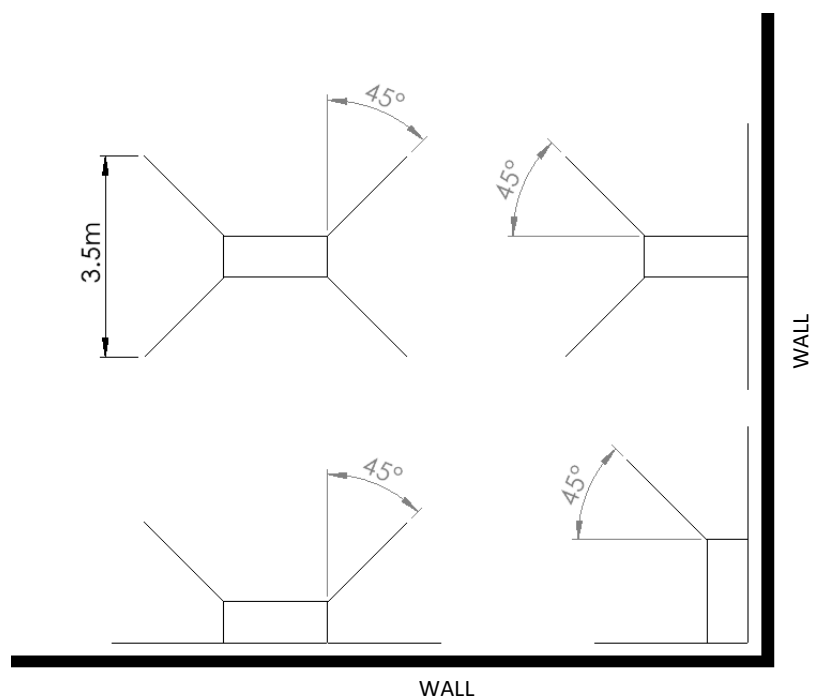

700 Foldout

Configurations to BSEN 1004:-1:2020

Working Height (M) Platform Height (M)

Description	2.8 0.8	3.8 1.8	4.5 2.5	5.5 3.5	6.3 4.3	7.3 5.3	8.05 6.05
Castors	4	4	4	4	4	4	4
Base Unit	1	1	1	1	1	1	1
700 x 4 Rung Frame	0	2	0	2	0	2	0
700 x 7 Rung Frame	0	0	2	2	4	4	6
1.8m Trap Door Platform	1	1	1	2	2	2	3
1.8m Horizontal Brace	4	5	5	9	9	9	13
2.1m Diagonal Brace	0	1	2	3	4	5	6
Folding Toe Board Set	1	1	1	1	1	1	1
Instruction Manual	1	1	1	1	1	1	1
S1 Stabiliser		*4	4	4	4	4	4
Approx. Tower Shelf weight (Kgs) 1.8m	66.3	81.5	120	156	166.5	179.8	213

* Please Note: Stabilisers for 1.8m are not required when using internally only externally. However it is the users responsibility to complete a risk assessment and decided if stabilisers are required internally as well.

Notes:

Notes:



KM 617169