

A SAFER WAY TO REACH NEW HEIGHTS

UTS 1450/850 LADDER AGR

Instruction Manual

Mobile Access Tower



Instruction Manual

This Assembly Guide is intended to provide you with step-by-step instructions on how to erect your Mobile Access Tower (MAT) with ease and safety, using the AGR (Advanced Guardrail System) method.

You should read and understand all notes and diagrams, including the parts list for each height, before commencing assembly. Personnel should be qualified or competent to erect this tower. Please consult the PASMA's code of practice for full information on the use of Mobile Access Towers.

Remember to do a risk assessment of the area where the tower is to be used before commencing erection.

This instruction manual shall be available on the location of use of the mobile access and working tower.

This mobile access and working tower shall only be used according to this manual without any modification.

Manufactured to: BSEN1004-1:2020 CLASS 3 8/8 XXXD H2

T&RGETMARK[®]
CERTIFIED

BS EN 1004-1:2020
BS EN 1004-2:2021

TM1008
testandresearch.org



 **MADE IN
BRITAIN**

HEALTH AND SAFETY WARNINGS

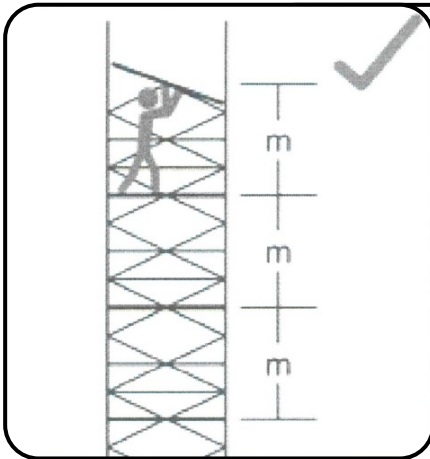

Maximum height between platforms of 2.2m

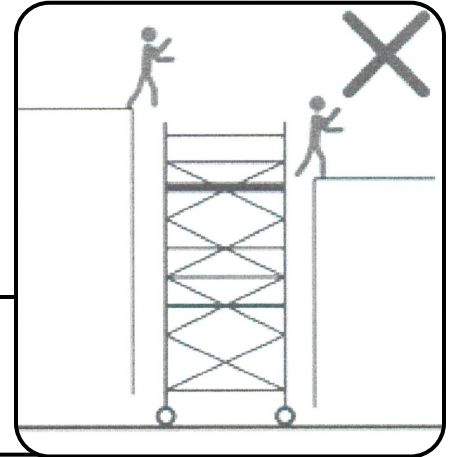

Do not use the tower as a form of access or exit

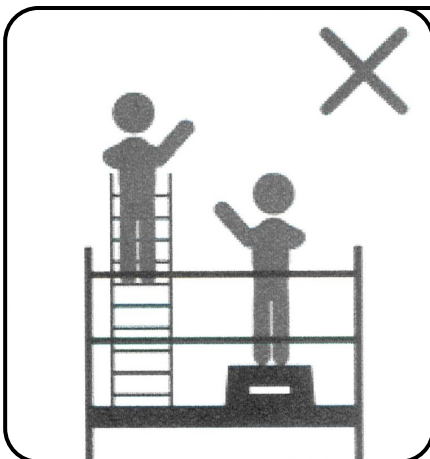

Do not use ladders, boxes or any other objects to gain additional

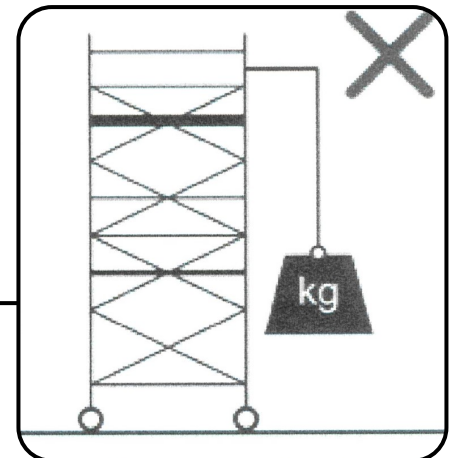

Do not lift heavy objects from the tower

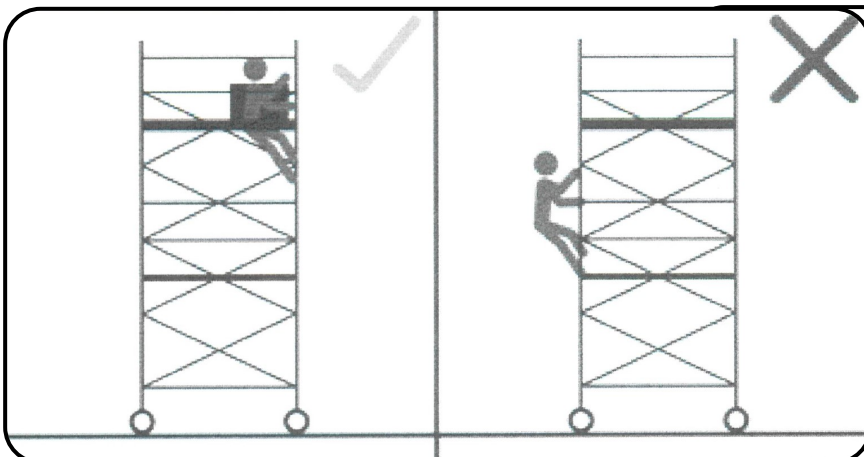

Do not climb outside of the tower, only climb up inside the tower.

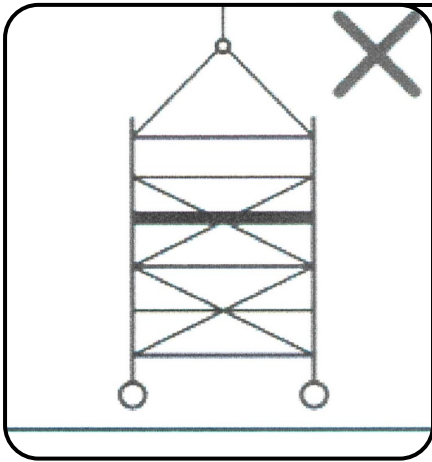

Do not suspend or lift the tower

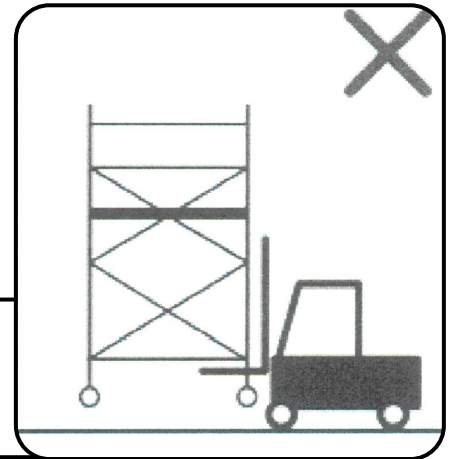

Do not lift the tower with mechanical equipment

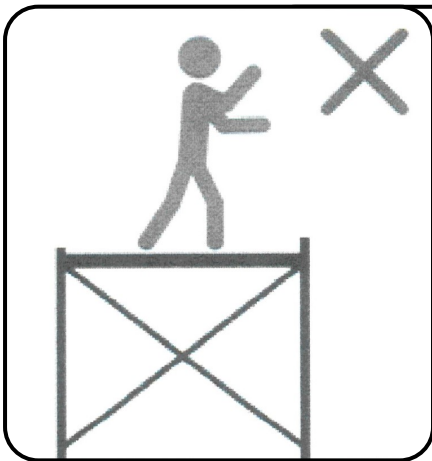

Do not stand up on an unguarded platform

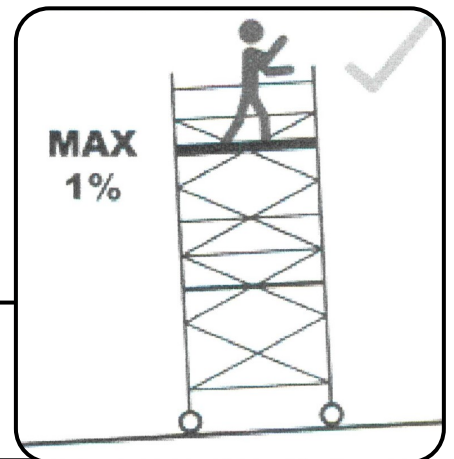

Maximum inclination for working = 1%

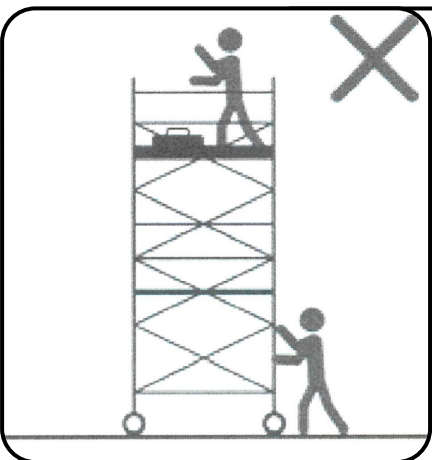

Do not move the tower with material or people on it

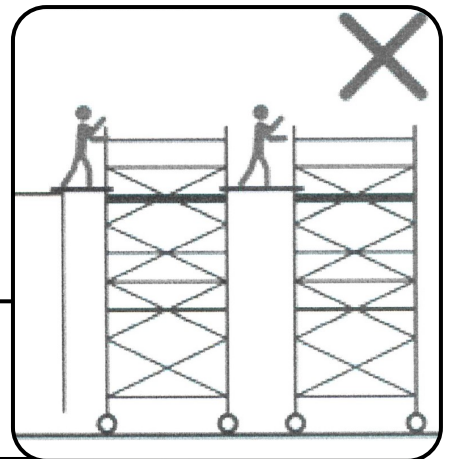

Do not bridge between towers or other structures

UTS 1450/850 LADDER AGR

Instruction Manual

Mobile Access Tower

Contents	Page
Description	5
Safety Notes & Fittings	5
Inspection Care and Maintenance	7
Components and Weights	11
Assembly	12
Dismantling	19
Configurations and Weights	20
Risk Assessment Form	22

Description, Safety Notes & Fittings

Description

The UTS 1450/850 Ladder AGR tower is manufactured to BSEN1004-1:2020 CLASS 3 8/8 XXXD H2 and TARGET MARKED. The TARGET MARK is a recognised symbol that reassures the user that the product is certified to BSI stated standards.

The UTS 1450/850 Ladder AGR tower is a lightweight aluminium industrial tower designed for use in a variety of commercial and domestic environments. It gives a safe and secure and robust work area at a range of heights indoors and outdoors to enable maintenance, installation work and short term access, ensuring that working at height is as safe as possible.

- Instructions for erection and use to be followed carefully.
- The UTS 1450/850 Ladder AGR has a maximum working platform height of 8.2 meters outdoors and 8.2 meters indoors.
- This is a Load Class 3 MAT, therefore maximum permissible load on the UTS 1450/850 Ladder AGR tower is 950kgs and evenly distributed on each platform is 275kgs. This must not be exceeded over the working height platforms, not including rest platforms.
- Maximum of 1 working platform per tower.
- Maximum of 2 people per working platform.
- Damaged or incorrect components shall not be used.

Risk analysis

Proper risk analysis of our towers reveals that all components are integral to the safety of the tower once assembled, and while assembling is the greatest period of risk. If the user follows the instructions set out in this manual it will contribute to the reduction of risk of injury, this along with the PASMA training recommended in the manual should be enough to significantly reduce the risk possibility down to improbable if not impossible.

The components have been designed in such a way that they can be assembled in an order that allows for minimal risk to occur, such as making locking parts easy to lock but harder to unlock to ensure easy assembly but prevent accidental removal during use, and colour coding parts that are harder to distinguish between. Instructions in the manual and training courses are very clear about how to access the tower and the correct method is displayed on the tower as a reminder, but ensuring all components and materials are of the highest standard, means we can be confident that even if misuse was to occur, we can be confident that the components would be able to still prevent injury.

It is important to limit the risk of all tasks especially when working at height. It is the user's responsibility to complete a risk assessment then use that to reduce the risk associated with the task (a blank one can be found at the back of this manual). Once the full risk assessment is completed and all hazards have been identified and controlled it is down to the user to decide if there is still too much risk in which case do not erect or use tower and look for alternative access arrangements.

Safety Notes

ERECTION & DISMANTLING - THE AGR (Advanced Guardrail System) METHOD

Towers should be erected following a safe method of work, there are two approved methods recommended by 'Prefabricated Access Suppliers & Manufacturers Association' (PASMA) in co-operation with the Health and Safety Executive (HSE) & the "working at height regulations 2005"

The method used for erecting and dismantling the UTS 1450/850 Ladder AGR tower is the AGR Method.

This method ensures the operators erecting the tower position themselves on a guarded platform to add or remove advanced guardrails for the next level up.

NEVER STAND ON AN UNGUARDED PLATFORM.

Before assembly or erection of this Mobile Access Tower (MAT) please ensure that:

- A risk assessment has been done and all safety equipment is on site.
- The ground conditions will take the working loads of MAT as specified.
- Always check that the MAT is vertical, (Level, slope, uneven ground etc.) if levelling is required make sure you adjust legs, in line with instructions (use spirit level).
- Beware of (overhead) obstructions – live wires, electrical apparatus or moving parts of machinery or other.
- Wind conditions are within limits as specified. (Refer to page 7)

- If in doubt DO NOT ERECT.
- Check that all components are on site and that they are in good working order before use (refer to the components and quantities shown at each stage). Auxiliary equipment and safety equipment. (ropes, etc)
- All platforms MUST have advanced guardrails fitted.
- The tower should always be accessed from the inside using the rungs of the end frames.
- Never climb up the outside.
- Use of Scaffolding tags or similar is required during use to ensure all correct safety information is on display; **MUST INCLUDE:**
 - The name and contact details of the responsible person.
 - If the tower is ready for application or not.
 - The load class and the uniformly distributed load.
 - If the mobile access and working tower is intended for indoors use only.
 - The date of assembly.
- Do not use the advanced guardrail braces as a rung or step.
- It is recommended that 2 persons erect this tower.
- The assembled tower should not be used as a means to enter or exit other structures, e.g. as a stair tower.
- Beware of horizontal forces (e.g., when using power tools on an adjacent structure), which could generate instability or overturning of the tower.
- Maximum distance between platforms is 2.25m, maximum distance to the first platform is 3.4m.
- Maximum horizontal force 20kgs.
- Mobile access and working towers are not designed to be sheeted
- The tower height used should be appropriate for the working height, e.g. within 2 meters above the platform
- User training courses cannot be a substitute for instruction manuals but only complement them.
- Only the original UTS components specified in the manual shall be used.
- Mobile access and working towers designed in accordance with BS EN 1004-1:2020 are not anchor points for personal fall arrest equipment.
- Working is only permitted on a platform with a complete side protection including guardrails and toe boards.
- Mobile access and working towers are not designed to be used as edge protection.

STABILISERS & BALLAST

Stabilisers or outriggers and ballast shall always be fitted when specified. When using the MAT externally stabilisers must be fitted. Should ballast be required, a platform should be positioned on the lowest rung and the weights should be firmly attached to it and evenly distributed. For advice on ballast contact your supplier.

MOVING THE TOWER AND LEAVING IT UNATTENDED

- Adjust the stabilisers to provide ground clearance.
- Unlock the castor wheels.
- Move with manual force only, and only from the base.
- Beware of (overhead) obstructions – live wires, hanging apparatus or other objects.
- Do not move with people or material on the tower.
- Do not move the assembled MAT if wind speeds exceed a moderate breeze.
- When moving the tower over uneven or sloping ground remove all tools.
- Do not move the assembled tower if over 4 meters high.
- Mobile access and working towers shall only be moved on a flat and solid ground without obstacles and not on a slope of more than 10mm/1m
- It is recommended that towers should be tied to a solid structure, when left unattended.
- Recheck that the MAT is vertical or needs readjustment of legs before ascending. (Using spirit level)
- Relock Caster brakes and readjust the stabilisers once in the new position before ascending.
- Check to make sure all components are there before using after moving or leaving unattended.

LIFTING OF EQUIPMENT

Tools and other equipment should be hauled up by a person on the platform using rope or similar, through the trapdoor of the platform or within the tower footprint.

Please see footprint guide on page 19.

Safe working loads of platform and tower not to be exceeded.

LIFTING OF INDIVIDUAL TOWER COMPONENTS

Raising and lowering components, tools and/or materials by rope should be conducted within the tower base (i.e. within the area bounded by the stabilisers). Ensure that the safe working load of the supporting decks and the tower structure is not exceeded.

Check for environmental changes before every use. (i.e.: all weather conditions).

TIES

When ties are required, they should be in accordance with table 17 of BS 5973:1990 and table 24 of BS 5975:1982.

Always tie to a solid structure.

The tie frequency should be at 4 meter intervals or less vertically.

CHECK LIST, INSPECTION CARE AND MAINTENANCE FOR MOBILE ACCESS TOWERS

- All components should be inspected before use to ensure that they are not damaged or broken, particularly the welds.
- ANY damage to ANY part particularly tubular members, castors, platform decking MUST be replaced.
- Adjustable leg threads should be cleaned and lightly oiled.
- All locking claws should be cleaned, and the locking mechanism checked for operation.
- When storing your MAT, please ensure that all components are neatly stored and not left lying around where they could be stood on or damaged.
- When transporting the MAT always tie the components down so that they do not move around and get damaged.
- Should the tower be left unattended it should be tied to a suitable structure and on reuse ALWAYS check that the tower is vertical and safe before ascending correct and complete structure.
- The MAT is not designed to be lifted or suspended as a complete structure.
- Always keep this instruction manual safe.
- Broken, damaged or incorrect components must never be used. The equipment shall be quarantined and assessed for replacement repair or destruction.

WIND EFFECTS

- Beware of high, gusty, or moderate breeze conditions in exposed areas. It is recommended that in wind speeds over a

Wind	Beaufort Scale 10 Meters above ground	Force	Speed in m.p.h.	Speed in knots
Moderate Breeze	Raises dust and loose paper, small branches move.	4	13–18	11–16
Strong Breeze	Large branches in motion, telegraph wires whistle.	6	25–31	22–27
Gale Force	Walking is difficult, twigs break off trees.	8	39–46	34–40

Moderate Breeze (see Beaufort Scale below) that work on the tower is stopped and reassessed. If the wind becomes a Strong Breeze, (see Beaufort Scale below) the tower should be tied to a rigid structure. If the wind is likely to reach Gale Force (see Beaufort Scale below) or over, work should be stopped, and the tower should be dismantled.

- Beware of tunnelling effect caused by open ended buildings, uncladded buildings and building corners.

LOCKING CASTORS

Castor wheels should be pointed outwards at approximately 45 degrees and locks engaged as shown opposite.

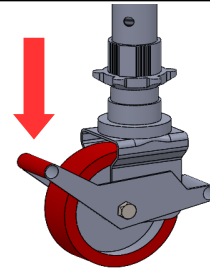

BRACE CLAMP LOCKING

Ensure that the brace clamp is locked as shown.

Always make sure the brace is not clamped too close to the weld as indicated by the arrow on the drawing on the right.

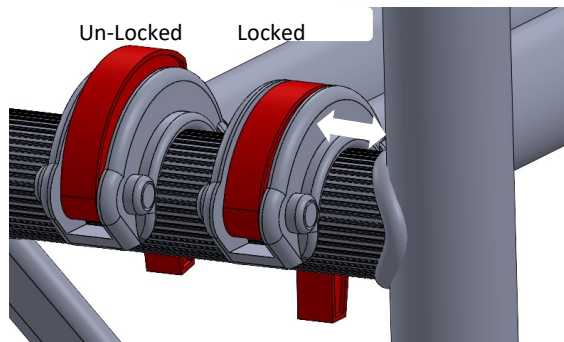

CORRECT FITTING OF HORIZONTAL BRACING

THE CORRECT FITTING OF HORIZONTAL BRACING IS IMPORTANT.

The diagrams opposite illustrate the CORRECT brace positions.

REMEMBER: Always fit braces DOWNWARD or from the inside facing OUTWARD – BUT NEVER INWARD

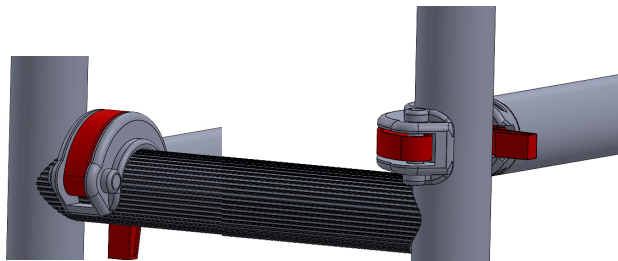

LOCKING CLIPS

Fit the locking clips as shown in the diagram opposite.

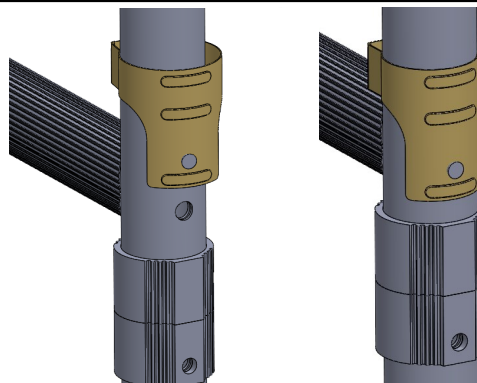

FITTING ADJUSTABLE LEGS

Take the adjustable leg assembly complete with its castors, make sure that all the adjusting nuts are positioned down at the castor and slide them into the vertical tube, turn the base unit the right way up and with the aid of a spirit level placed on the platform, the adjusting nuts can be used to level the structure. (and not to gain additional height).



AGR CLAMP LOCKING

Hook over AGR clamp

Unscrew palm wheel

Then rotate bottom block into locked position.

Retighten palm wheel.

ALWAYS ENSURE BOTH BOTTOM AGR CLAMPS ARE LOCKED BEFORE CLIMBING UP TOWER TO LOCK TOP AGR CLAMPS.

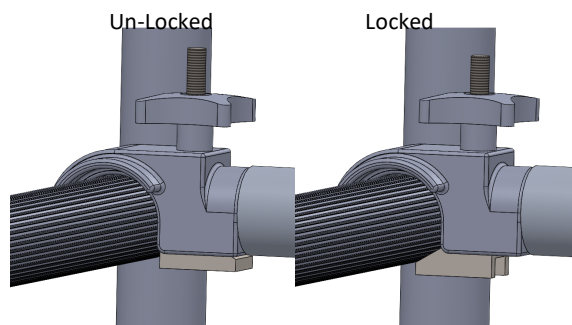

FITTING STABILISERS

To attach stabilisers clamps, undo palm wheel all the way, fit one side of clamp to vertical frame, then rotate second side of clamp to fit vertical frame and tighten palm wheel.

Attach a stabilisers in configurations as shown on pg18 for maximum stability in

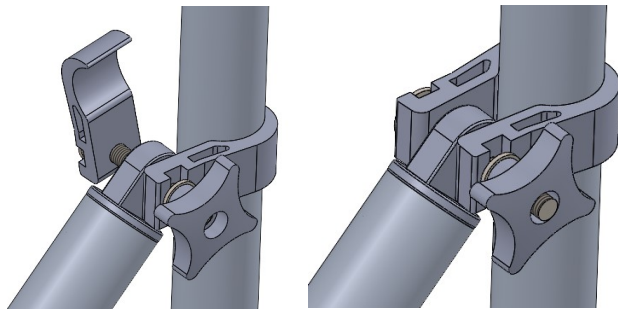

PLATFORM WINDLOCK LOCKING

Make sure wind locks are pushed forward until they sit securely under the rung.

They should not be able to fall out and should require a reasonable pull to disengage them.

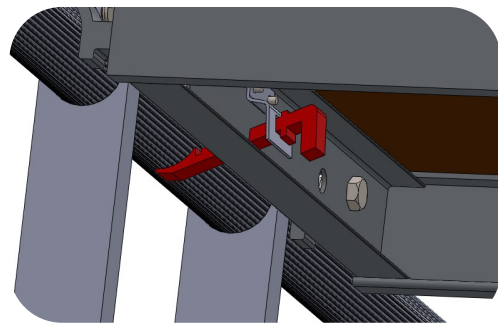

FITTING TOE-BOARDS

4 piece wooden planks
and clips.

Fit toeboard clip to each
corner of the platform(s).
Ensure clip straddles
platform hooks and line
up correctly with outside
edge of platform.

Fit planks to inside slot at
ends of platform and into
the back slot for the
edges.

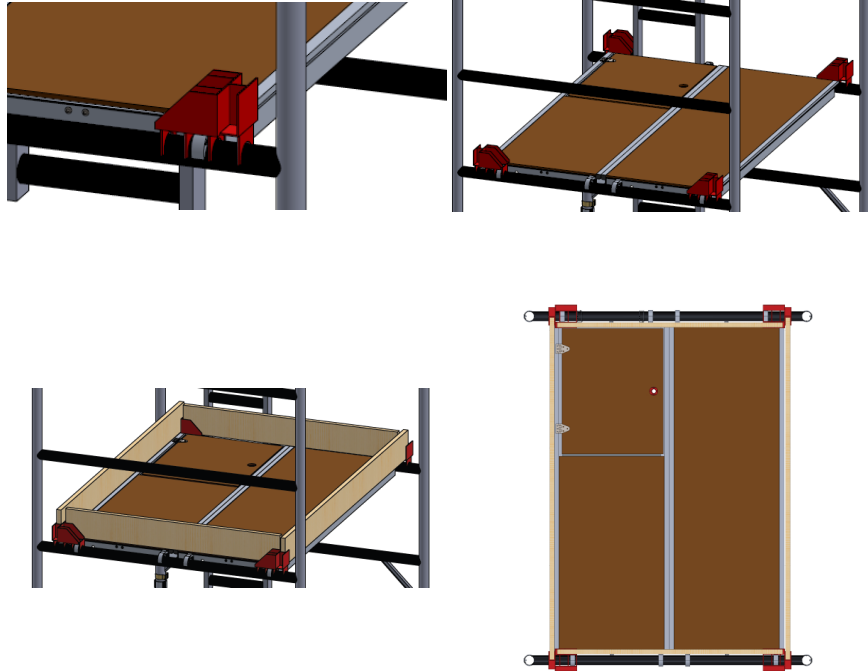

FITTING TOE-BOARDS

1 piece folding aluminium toe
board.

Unfold out over platform, hook
bottom edges over sides of
platform.

Ensure short ends of toe boards
have hooked over both ends of
the platform, hook bottom edge
down between platform hook
and frame.

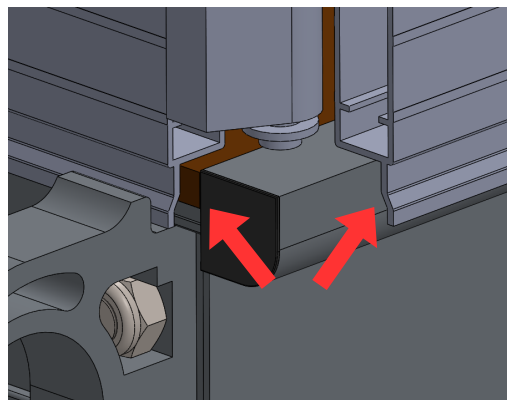
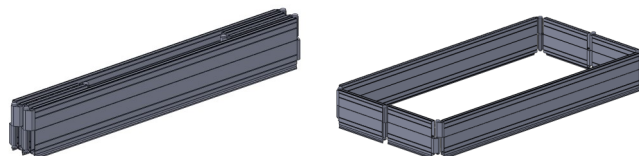

Identifying Components and Their Weights

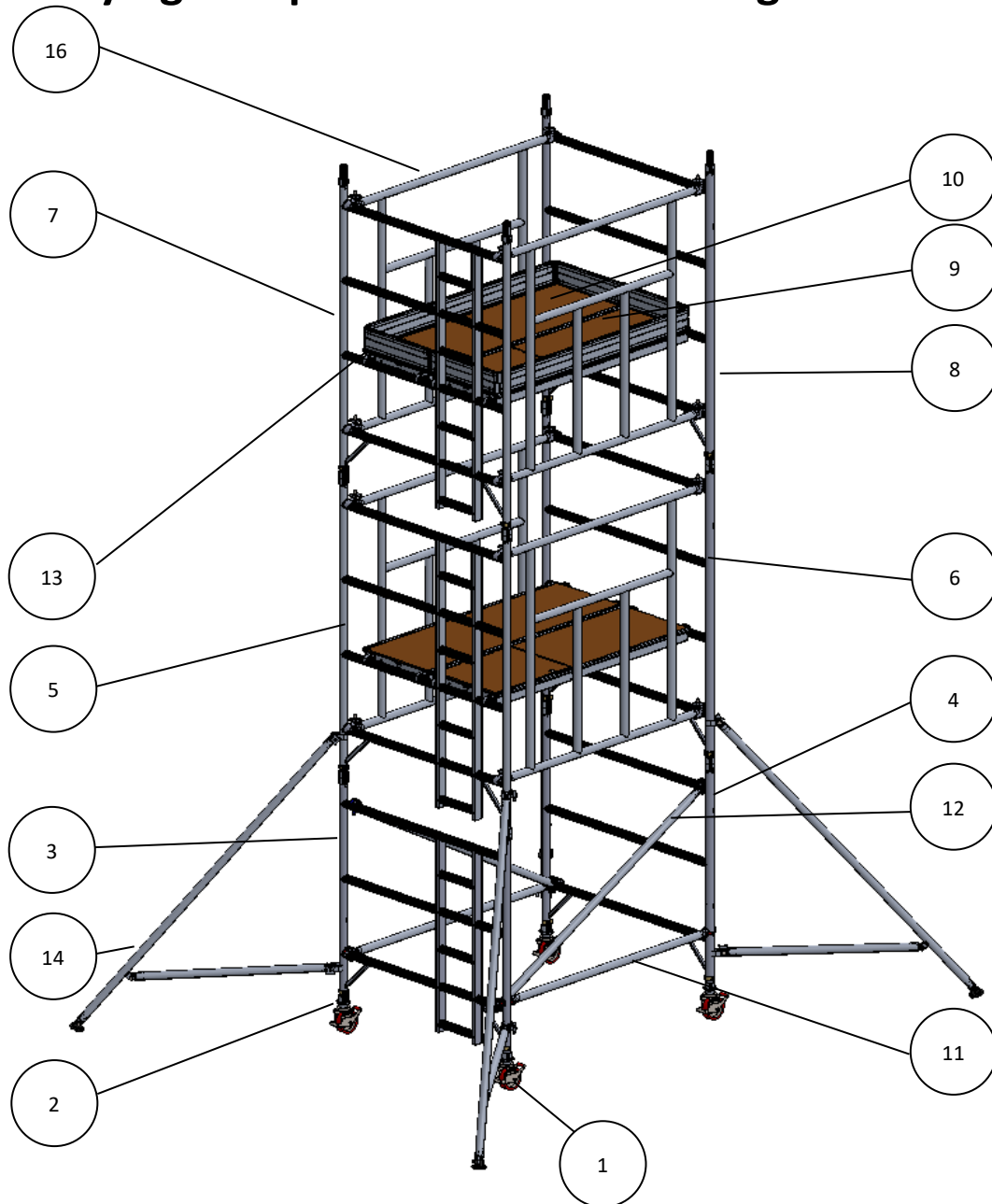

Note:

When building structures over 4.2 metres remove platform and 4 horizontal braces from platform height at 2.2 meters and use to complete structure.

Tower Components and Approx. Weights

Item	Description	Weight (Kg)	Item	Description	Weight (Kg)
1	150mm Locking Caster	3.4	9	1.8m Trapdoor Platform	12.7
2	Adjustable Leg 500mm	1.1	10	1.8m Fixed Platform	11.8
3	1m Ladder Frame	5.4	11	1.8m Horizontal Brace	2.1
4	1m Span Frame	4	12	2.1m Diagonal Brace	2.2
5	1.5m Ladder Frame	8	13	Complete Toe Board Set	14
6	1.5m Span Frame	5.6	14	S1 Stabiliser	4.1
7	2m Ladder Frame	10.4	15	S2 Stabiliser	5.9
8	2m Span Frame	7.1	16	1.8m AGR	8.5

Assembly Procedure

UTS recommends that a minimum of two people is required for the assembly of the UTS 850/1450 LADDER AGR tower. Only climb the tower from the inside using the ladder section.

Platform Heights in Meters	Frame at Base	Second frame
2.2, 4.2, 6.2, 8.2	2 Rung	4 Rung
2.7, 4.7, 6.7	3 Rung	4 Rung
3.7, 5.7, 7.7	2 Rung	3 Rung

Use this table to configure the tower build, start as shown and add 4 rung sides as needed.

Example 3.7m Platform height assembly

1. Insert adjustable leg assembly (with castors or base plates) into the base of ladder frame, repeat this with the span frame. Lock all castor wheels

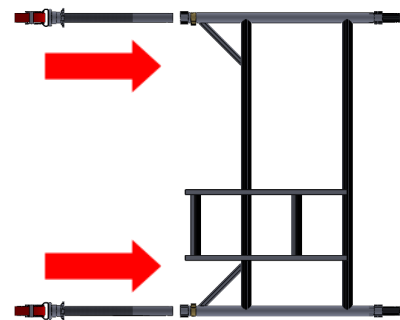

2. Attach one horizontal brace to the bottom rung of the span frame, claws facing downwards. This frame will now be self-supporting.

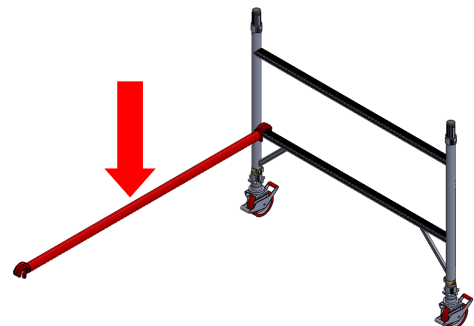

3. Position the ladder frame as shown. Connect the other end of the horizontal brace to the ladder frame. Now connect the frames using a second horizontal brace on the opposite side, attach from the inside of the frame just above the bottom rung, claws facing outwards, this will square the tower.

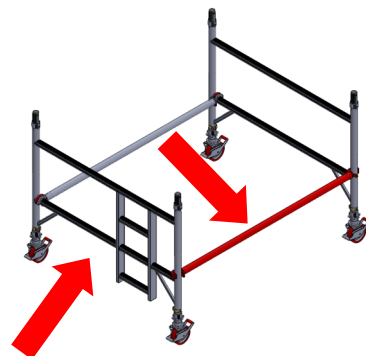

PLEASE TAKE NOTE

Never place the platform on the guardrail frame

Always climb from the inside of the frame – never the outside.

When working on the platform never overreach

Insert 3 rung frames to correspond with the 2 rung frames (fig. 3) and lock the locking clips (refer to page 9).

4.

Attach diagonal braces on both sides from the 1st rung to the 3rd rung of the structure, in opposing directions.

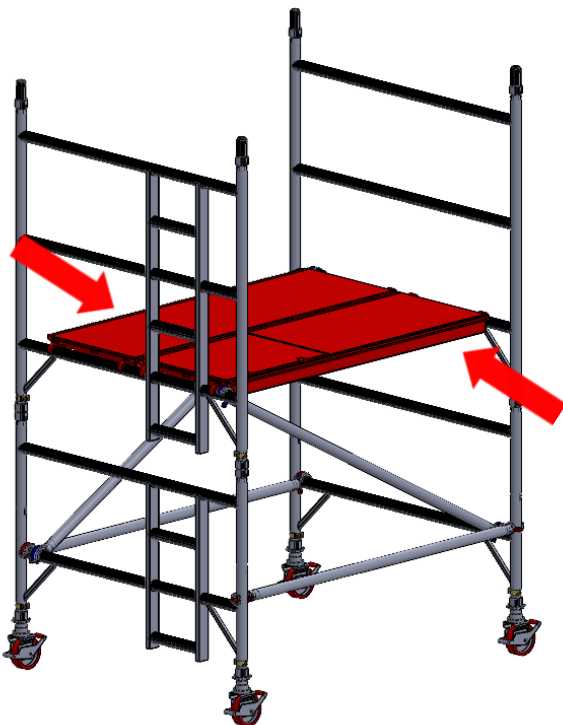
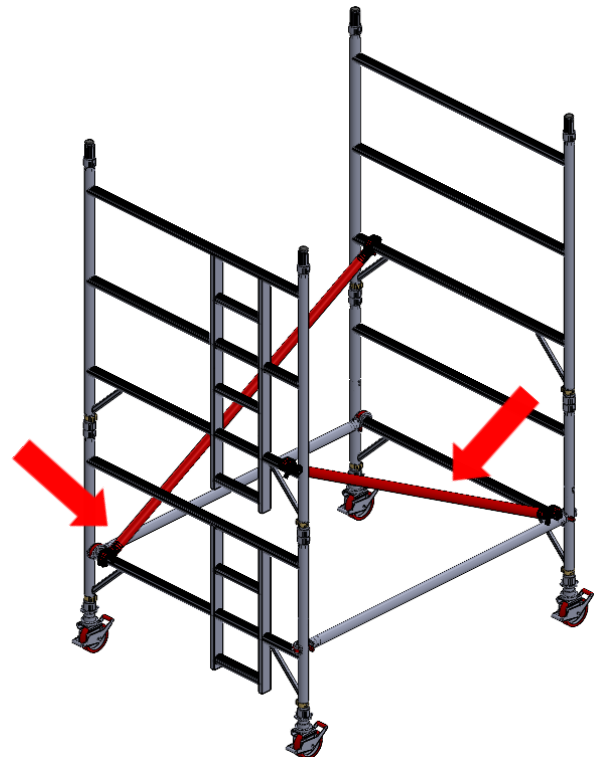
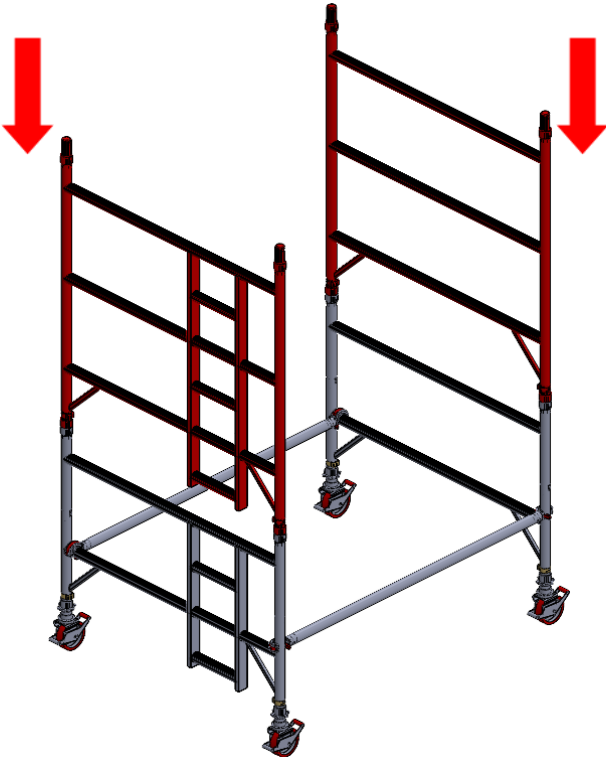

Attach stabilisers as required for working height (see table page 20).

Fit a AGR on each side of the tower. The bottom of the AGR must be fitted to the 2nd rung of the tower, as shown. The AGR should be placed up against the end frame verticals.

5.

Make sure bottom AGRs are locked before you climb tower. (refer to page 9)

Never climb onto a platform that is not fully guarded. Guardrails should enclose platform as show in images.

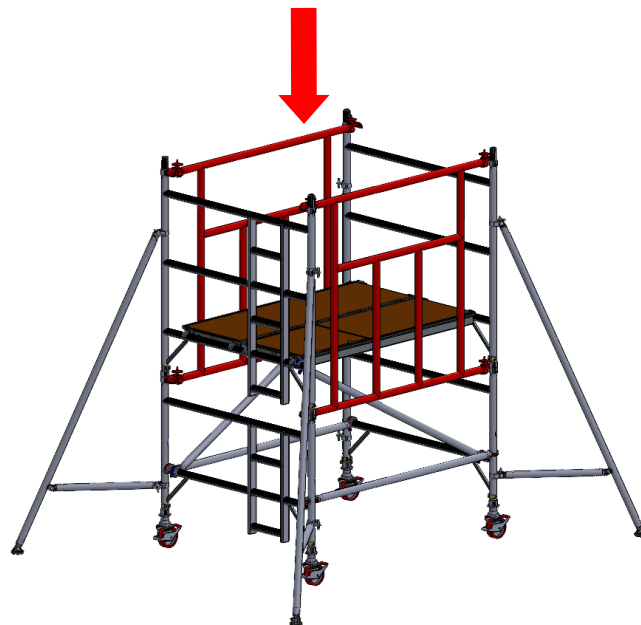
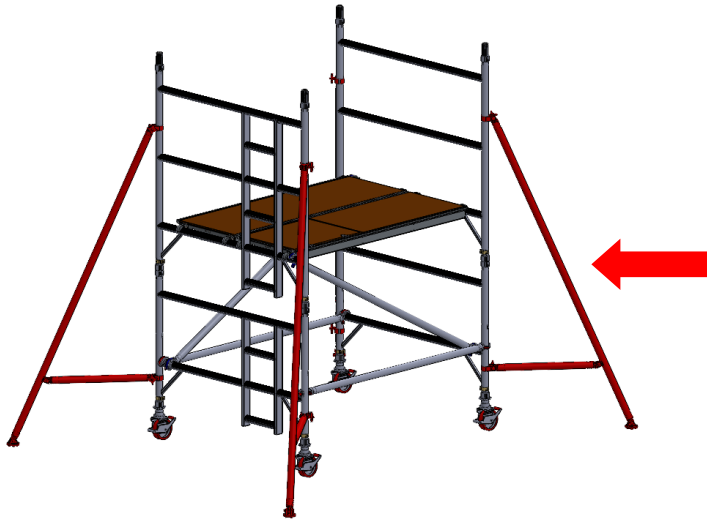

6. Attach the 4 rung frames and lock clips.



7.

Fit a AGR on each side of the tower. The bottom of the AGR must be fitted to the 1st rung of the 4 rung sides, as shown. The AGR should be placed up against the end frame verticals. Make sure bottom AGRs are locked before you climb tower. (refer to page 9)

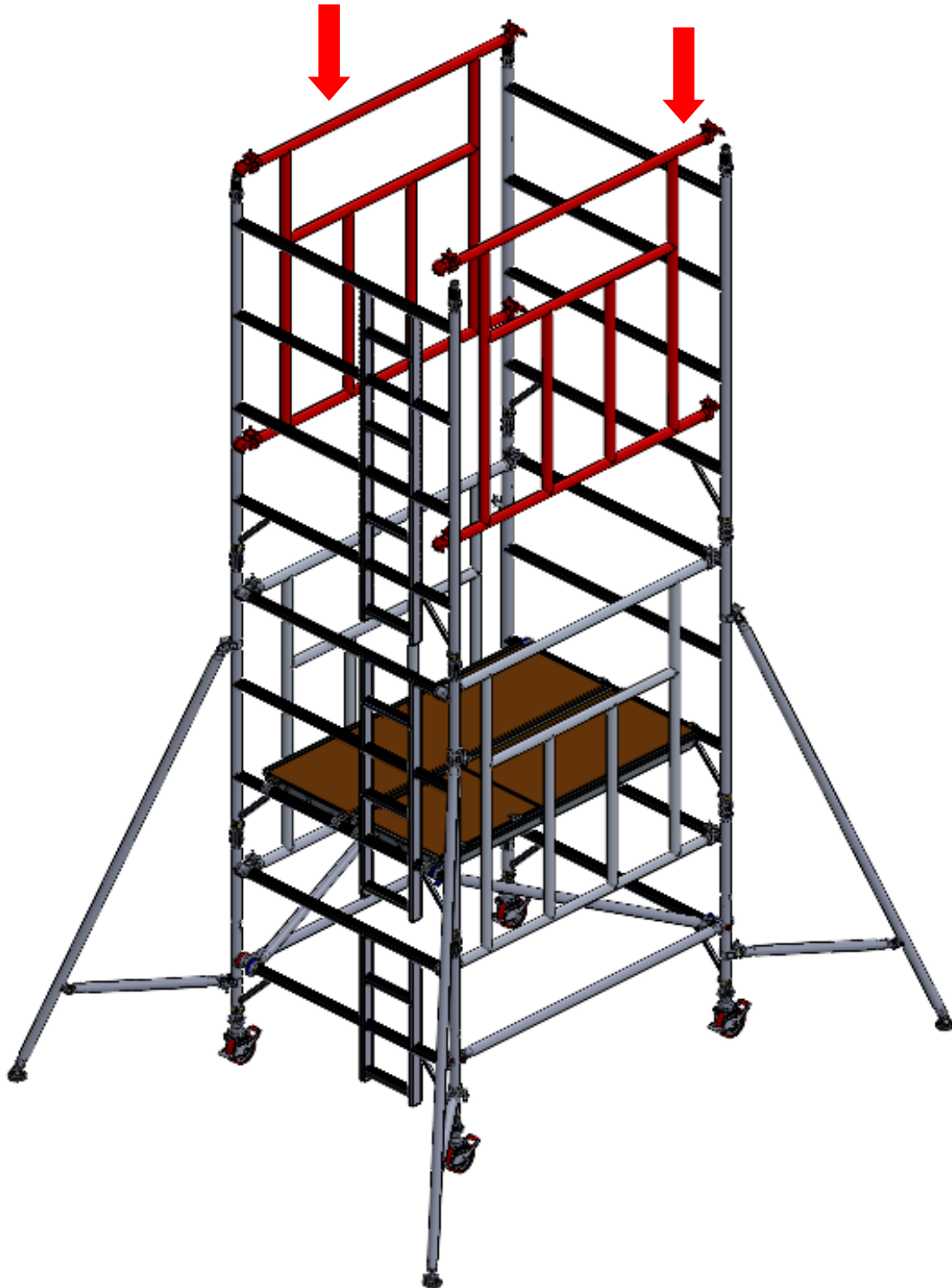

Place a trap door platform and a fixed platform on the 2nd rung of the 4 rung frame, ensure the trap door platform is on the ladder side of the structure.

8.

LOCK WIND LOCKS.

If completing the tower at this height (3.7m), continue with step 9.

When building beyond this level ensure correct size frames have being used in steps 1-5 for the desired

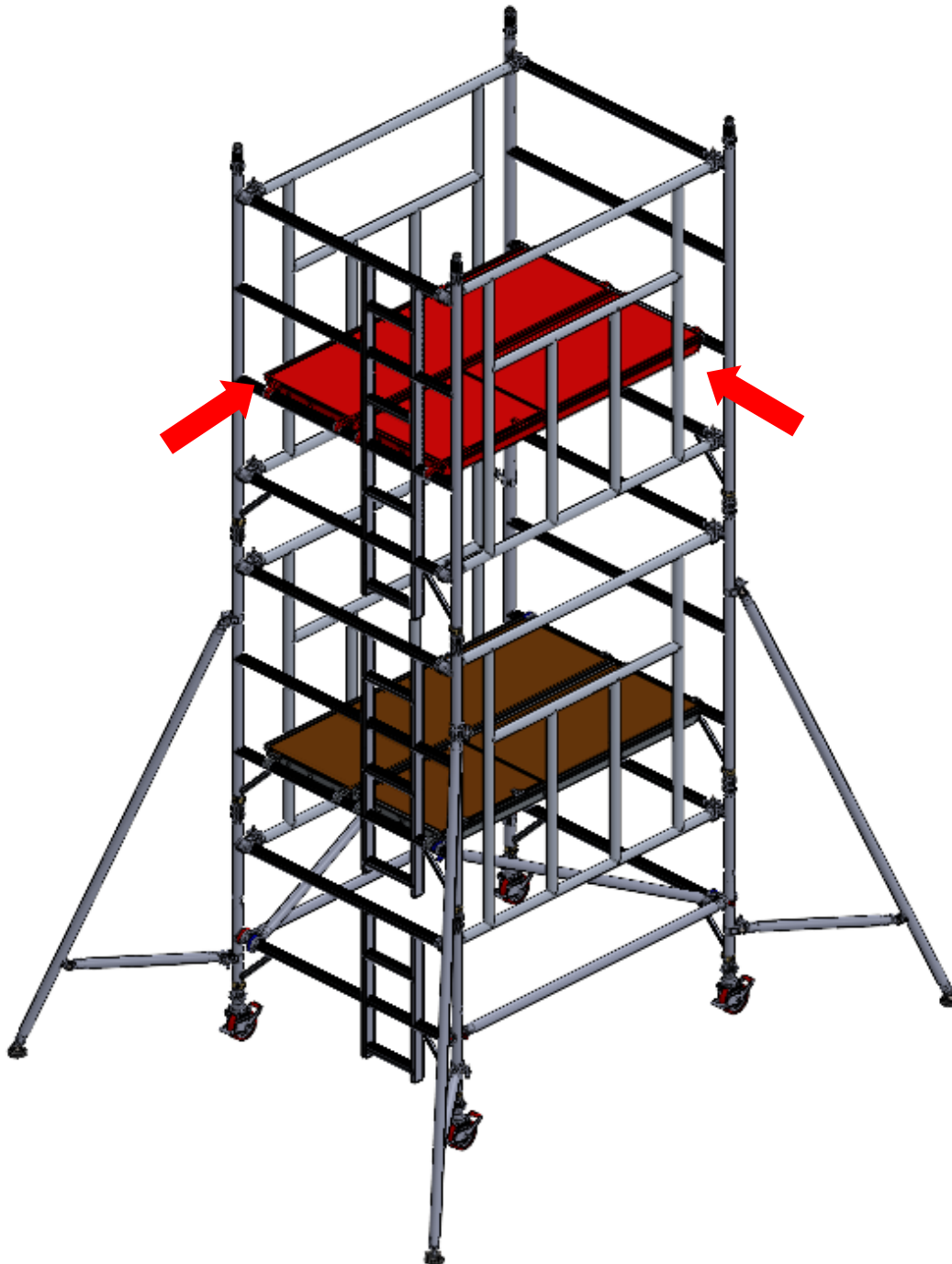

9. Fit toe boards to all working platforms either folding aluminium or toeboard clips and planks.
(see instructions on page 9)



Maximum distance between platforms should not exceed 2.25m.

Maximum distance to first platform should not exceed 3.4m

Dismantling

The dismantling procedure should follow the assembly steps in reverse order, take particular attention about the removal of guardrails and platforms.

You should ensure that you are standing in a safe position and always protected by guardrails NEVER remove braces or stabilisers prematurely.

After removing the toe-boards the operator changes the top ARG clamps to the unlocked position, then descends to the lower level. Then the platforms above the operator can be removed, then the bottom AGR clamps can be unlocked and AGR removed from the Tower.

NOTES:

DO NOT OVER-REACH and NEVER DROP COMPONENTS when dismantling always lower them to the ground.

STABILISERS

Attach one stabiliser to each corner of tower at approx. 45 degrees. The bottom clamp should be fitted as low as possible, refer to the diagram opposite. Ensure that all four rubber feet are in contact with the ground and that the clamps are secured. Position stabilisers as shown in the diagrams.

When moving the tower lock each telescopic leg just clear of the ground, unlock castors ensuring area is firm and clear of all obstructions both on the ground and above.

After moving check all castors are firmly on the ground and locked, and that the tower is vertical. Re-position stabilisers as above.

When using tower near a wall or in a corner, the stabiliser layout needs to be adjusted to accommodate.

As shown in the diagram if against a wall 2 stabilisers should be made parallel to the wall and the others should remain at 45°.

If being used in a corner, the closed

STABILISERS—S1

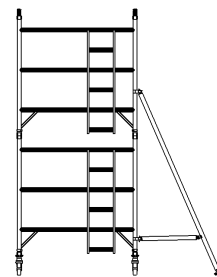
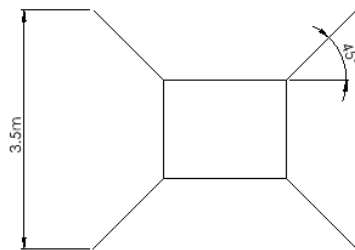

Static Stabiliser maximum platform height

Single Width 850

Indoors 8.2m, Outdoors 8.2m

Double Width 1450

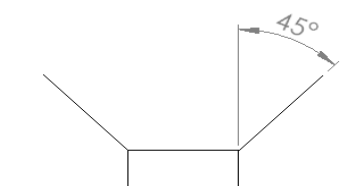
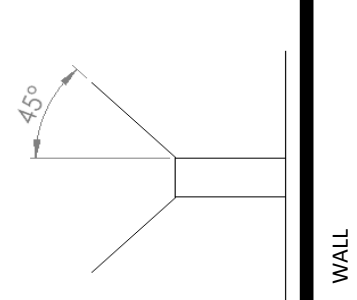
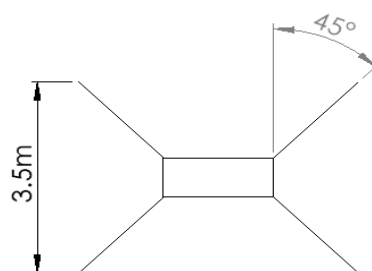

WALL

850 Single Width

Configurations to BSEN 1004:-1:2020

Available in two lengths: 1.8m & 2.5m

Working Height (M) Platform Height (M)

INTERNAL AND EXTERNAL USE

Description	Approx Kg	4.2	4.7	5.7	6.2	6.7	7.7	8.2	8.7	9.7	10.2
		2.2	2.7	3.7	4.2	4.7	5.7	6.2	6.7	7.7	8.2
Castors	3.4	4	4	4	4	4	4	4	4	4	4
Adjustable Leg Unit	1.1	4	4	4	4	4	4	4	4	4	4
850 x 2 Rung Ladder Frame	4.9	1		1	1		1	1		1	1
850 x 2 Rung Span Frame	3.7	1		1	1		1	1		1	1
850 x 3 Rung Ladder Frame	7.7		1	1		1	1		1	1	
850 x 3 Rung Span Frame	7.0		1	1		1	1		1	1	
850 x 4 Rung Ladder Frame	9.5	1	1	1	2	2	2	3	3	3	4
850 x 4 Rung Span Frame	9.0	1	1	1	2	2	2	3	3	3	4
1.8m or 2.5m Fixed Platform	11.8		1								
1.8m or 2.5m Trap Door Platform	12.7	1	1	2	2	2	3	3	3	4	4
1.8m or 2.5m Horizontal Brace	2.1	2	2	2	2	2	2	2	2	2	2
2.1m or 2.7m Diagonal Brace	2.2	2	2	2	2	2	2	2	2	2	2
1.8m or 2.5m AGR	9.1	2	2	4	4	4	6	6	6	8	8
S1 Stabiliser	4.1	4	4	4	4	4					
S2 Stabiliser	5.9						4	4	4	4	4
Toe Board Clips	0.3	4	4	4	4	4	4	4	4	4	4
Single End Plank	0.9	2	2	2	2	2	2	2	2	2	2
1.8m or 2.5m side Plank	2.8	2	2	2	2	2	2	2	2	2	2
1.8m or 2.5m Alluminium Folding Toeboard	8.5	1	1	1	1	1	1	1	1	1	1
Approx. Tower Shelf weight (Kgs)		109.4	127.3	155	158.8	164.9	211.6	215.4	221.5	261	264.8
Approx. Tower Shelf weight (Kgs)		109.5	127.4	155.1	158.9	165	211.7	215.5	221.6	261.1	264.9
Approx. Tower Shelf weight (Kgs)		120.6	142.7	174.4	178.2	184.3	239.2	243	249.1	296.8	300.6
Approx. Tower Shelf weight (Kgs)		121	143.1	174.8	178.6	184.7	239.6	243.4	249.5	297.2	301

1450 Double Width

Configurations to BSEN 1004:-1:2020

Available in two lengths: 1.8m & 2.5m

Working Height (M) Platform Height (M)

INTERNAL AND EXTERNAL USE

Description	Approx Kg	4.2	4.7	5.7	6.2	6.7	7.7	8.2	8.7	9.7	10.2
		2.2	2.7	3.7	4.2	4.7	5.7	6.2	6.7	7.7	8.2
Castors	3.4	4	4	4	4	4	4	4	4	4	4
Adjustable Leg Unit	1.1	4	4	4	4	4	4	4	4	4	4
1450 x 2 Rung Ladder Frame	5.4	1		1	1		1	1		1	1
1450 x 2 Rung Span Frame	4.2	1		1	1		1	1		1	1
1450 x 3 Rung Ladder Frame	8		1	1		1	1		1	1	
1450 x 3 Rung Span Frame	7.3		1	1		1	1		1	1	
1450 x 4 Rung Ladder Frame	10.4	1	1	1	2	2	2	3	3	3	4
1450 x 4 Rung Span Frame	9.9	1	1	1	2	2	2	3	3	3	4
1.8m or 2.5m Fixed Platform	11.8	1	2	2	2	2	3	3	3	4	4
1.8m or 2.5m Trap Door Platform	12.7	1	1	2	2	2	3	3	3	4	4
1.8m or 2.5m Horizontal Brace	2.1	2	2	2	2	2	2	2	2	2	2
2.1m or 2.7m Diagonal Brace	2.2	2	2	2	2	2	2	2	2	2	2
1.8m or 2.5m AGR	9.1	2	2	4	4	4	6	6	6	8	8
S1 Stabiliser	4.1	4	4	4	4	4					
S2 Stabiliser	5.9						4	4	4	4	4
Toe Board Clips	0.3	4	4	4	4	4	4	4	4	4	4
Double End Plank	1.8	2	2	2	2	2	2	2	2	2	2
1.8m or 2.5m side Plank	2.8	2	2	2	2	2	2	2	2	2	2
1.8m or 2.5m Alluminium Folding Toeboard	10.5	1	1	1	1	1	1	1	1	1	1
Approx. Tower Shelf weight (Kgs) Toe-		125.8	143.3	183.8	188.8	194.5	254	259	264.7	317	322
Approx. Tower Shelf weight (Kgs) Alu-		141.2	162.9	211.6	216.6	222.3	294.2	299.2	304.9	369.6	374.6
Approx. Tower Shelf weight (Kgs) Toe-		126.1	143.6	184.1	189.1	194.8	254.3	259.3	265	317.3	322.3
Approx. Tower Shelf weight (Kgs) Alu-		141.3	163	211.7	216.7	222.4	294.3	299.3	305	369.7	374.7

RISK ASSESSMENT COMPLETION FORM

NO	DATE
Site & Location	
Assessment carried out by:	
Signed	
MAIN ACTIVITY/SITUATION	
Public	

NOTE		
A – Personnel at Risk Employee <input type="checkbox"/> E Contractor <input type="checkbox"/> C Public <input type="checkbox"/> F	B – Severity Negligible <input type="checkbox"/> 1 Minor Injury <input type="checkbox"/> 2 Serious Injury <input type="checkbox"/> 3 Major Injury <input type="checkbox"/> 4	C – Probability Impossible <input type="checkbox"/> 1 Improbable <input type="checkbox"/> 2 Remote <input type="checkbox"/> 3 Occasional <input type="checkbox"/> 4
Probable <input type="checkbox"/> 5 Frequent <input type="checkbox"/> 6		

NO	Activity/Location Materials/Tools etc.	Hazards Identified	A	B	Risk Rating (B x C)	Equipment to be used to minimise risk	B	C	Risk Rating (B x C)	Action By

Risk value key: 1 – 4 = Acceptable, 5 – 9 = Medium – Investigate and where practicable reduce the risk, 10 – 14 = High – Action must be taken to reduce the risk
15 – 24 = VERY HIGH – RISK IS TOO HIGH TO START WORK OR CONTINUE, WORK MUST BE STOPPED

Notes:

Notes:



DOC NO: LT006, VERSION:1.3, DATE:01/03/24, APPROVED BY:A.GUNTRIPP, REVIEWED BY:M.GRANGER