

UTS FRP USER GUIDE

A SAFER WAY TO REACH NEW HEIGHTS

UTS 500 FRP 1450/850

Instruction Manual

Mobile Access Tower



Instruction Manual

This Assembly Guide is intended to provide you with step-by-step instructions on how to erect your Mobile Access Tower (MAT) with ease and safety, using the 3T (through the trap) method.

You should read and understand all notes and diagrams, including the parts list for each height, before commencing assembly. Personnel should be qualified or competent to erect this tower. Please consult the PASMA's code of practice for full information on the use of Mobile Access Towers.

Remember to do a risk assessment of the area where the tower is to be used before commencing erection.

This instruction manual shall be available on the location of use of the mobile access and working tower.

This mobile access and working tower shall only be



Manufactured to: EN1004-1:2020 CLASS 3 8/12 XXXD H2

HEALTH AND SAFETY WARNINGS

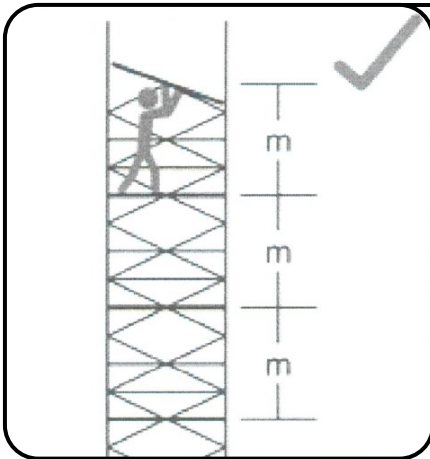

Maximum height between platforms of 2.2m

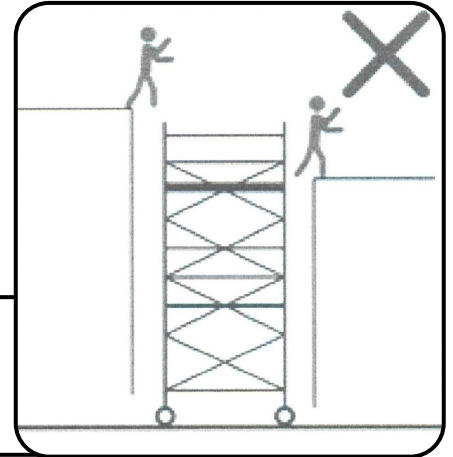

Do not use the tower as a form of access or exit

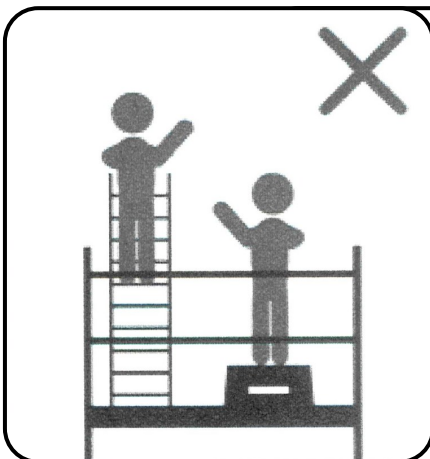

Do not use ladders, boxes or and other objects to gain additional

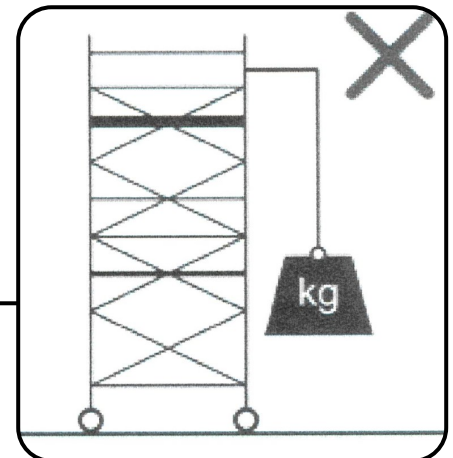

Do not lift heavy objects from the tower

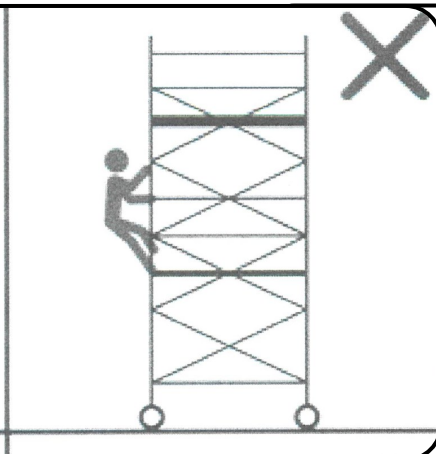
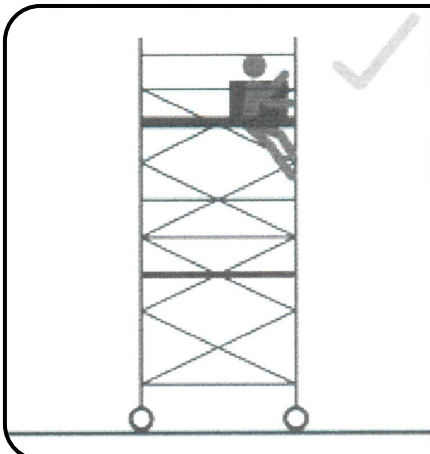

Do not climb outside of the tower, only climb up inside the tower.

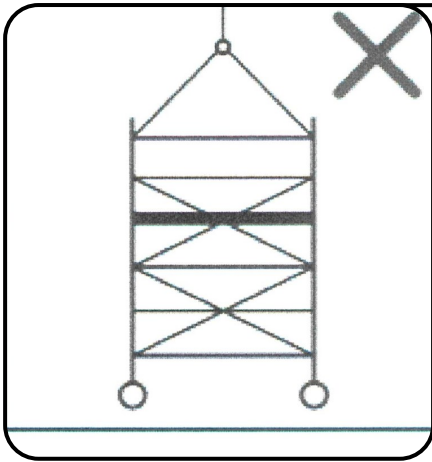

Do not suspend or lift the tower

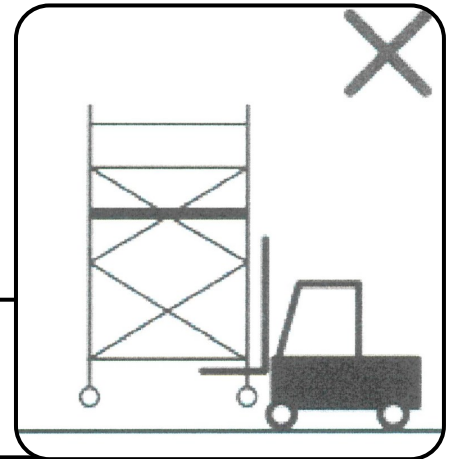

Do not lift the tower with mechanical equipment

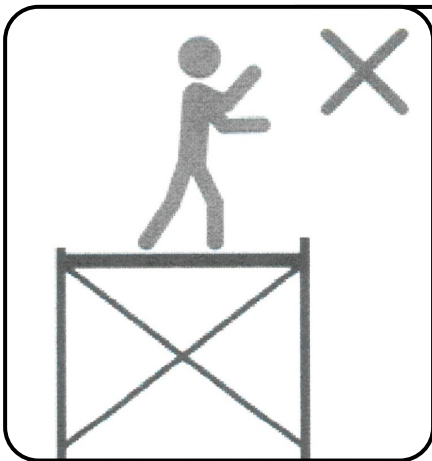

Do not stand up on an unguarded platform

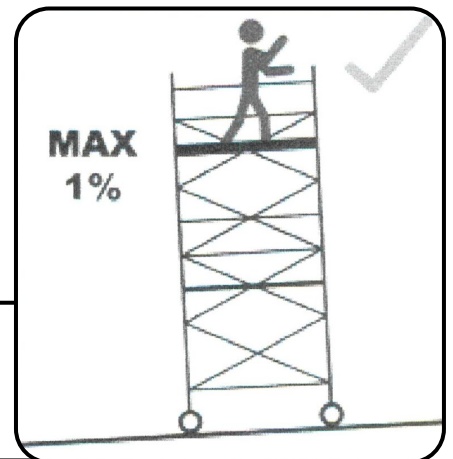

Maximum inclination for working = 1%

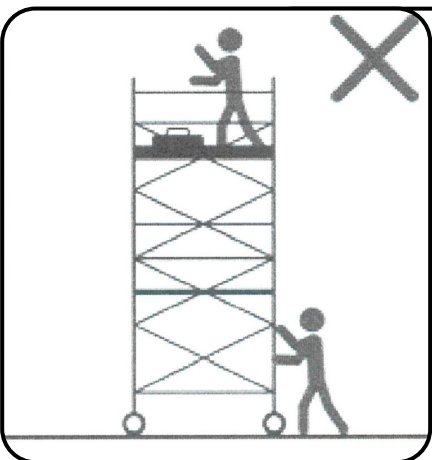

Do not move the tower with material or people on it

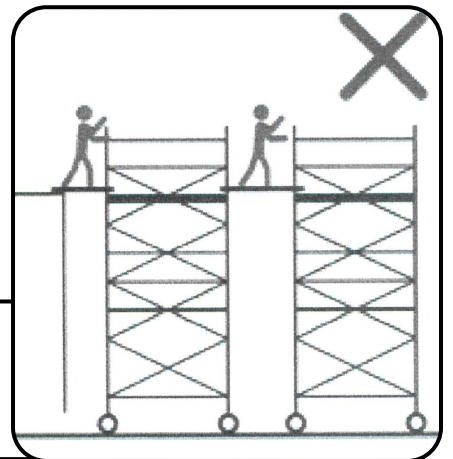

Do not bridge between towers or other structures

UTS 500 FRP 1450/850

Instruction Manual

Mobile Access Tower

Contents	Page
Description	5
Safety Notes & Fittings	5
Inspection Care and Maintenance	7
Components and Weights	11
Assembly	12
Dismantling	20
Configurations and Weights	21
Risk Assessment Form	23

Description, Safety Notes & Fittings

Description

The UTS 500 FRP 1450/850 tower is manufactured to EN1004-1:2020 CLASS 3 8/12 XXXD H2 and certified to EN stated standards by TUV.

The UTS 500 FRP 1450/850 tower is a FRP industrial tower designed for use in a variety of commercial and domestic environments. It gives a safe and secure and robust work area at a range of heights indoors and outdoors to enable maintenance, installation work and short term access, ensuring that working at height is as safe as possible.

- Instructions for erection and use to be followed carefully.
- A risk assessment should always be carried out before erecting your MAT (Mobile Access Tower).
- You will find a standard risk assessment form at the back of this instruction manual.
- The UTS 500 FRP 1450/850 has a maximum working platform height of 8.2 meters outdoors and 12.2 meters indoors.
- Ensure the safe working load on the structure is not exceeded. The number of people permitted on the tower at any time is limited by the safe working load.
- Platforms rated at 225kg UDL
- Tower Max safe working load 720kg.
- Maximum of 1 working platform per tower.
- Damaged or incorrect components shall not be used.

Risk analysis

Proper risk analysis of our towers reveals that all components are integral to the safety of the tower once assembled, and while assembling is the greatest period of risk. If the user follows the instructions set out in this manual it will contribute to the reduction of risk of injury, this along with the PASMA training recommended in the manual should be enough to significantly reduce the risk possibility down to improbable if not impossible.

The components have been designed in such a way that they can be assembled in an order that allows for minimal risk to occur, such as making locking parts easy to lock but harder to unlock to ensure easy assembly but prevent accidental removal during use, and colour coding parts that are harder to distinguish between. Instructions in the manual and training courses are very clear about how to access the tower and the correct method is displayed on the tower as a reminder, but ensuring all components and materials are of the highest standard, means we can be confident that even if misuse was to occur, we can be confident that the components would be able to still prevent injury.

It is important to limit the risk of all tasks especially when working at height. It is the user's responsibility to complete a risk assessment then use that to reduce the risk associated with the task (a blank one can be found at the back of this manual). Once the full risk assessment is completed and all hazards have been identified and controlled it is down to the user to decide if there is still too much risk in which case do not erect or use tower and look for alternative access arrangements.

Safety Notes

ERECTION & DISMANTLING - THE 3T(through the trap) METHOD

Towers should be erected following a safe method of work, there are two approved methods recommended by 'Prefabricated Access Suppliers & Manufacturers Association' (PASMA) in co-operation with the Health and Safety Executive (HSE) & the "working at height regulations 2005"

The method used for erecting and dismantling the UTS 500 FRP1450/850 tower is the 3T METHOD (through the trap).

This method ensures the operators erecting the tower position themselves in the trapdoor of the platform to add or remove horizontal guardrail braces for the level above the platform.

NEVER STAND ON AN UNGUARDED PLATFORM.

Before assembly or erection of this Mobile Access Tower (MAT) please ensure that:

- A risk assessment has been done and all safety equipment is on site.
- The ground conditions will take the working loads of MAT as specified.
- Always check that the MAT is vertical, (Level, slope, uneven ground etc.) if levelling is required make sure you adjust legs, in line with instructions (use spirit level).
- Beware of (overhead) obstructions – live wires, electrical apparatus or moving parts of machinery or other.

- Do not use boxes, ladders, or other devices on the platform to gain additional height.
 - If in doubt DO NOT ERECT.
 - Check that all components are on site and that they are in good working order before use (refer to the components and quantities shown at each stage). Auxiliary equipment and safety equipment. (ropes, etc)
 - All platforms MUST have horizontal guardrails fitted.
 - The tower should always be accessed from the inside using the rungs of the end frames.
 - Never climb up the outside.
 - Use of Scaffolding tags or similar is required during use to ensure all correct safety information is on display;
- MUST INCLUDE:**
- The name and contact details of the responsible person.
 - If the tower is ready for application or not.
 - The load class and the uniformly distributed load.
 - If the mobile access and working tower is intended for indoors use only.
 - The date of assembly.
- Do not use the guardrail braces as a rung or step.
 - It is recommended that 2 persons erect this tower.
 - The assembled tower should not be used as a means to enter or exit other structures, e.g. as a stair tower.
 - Beware of horizontal forces (e.g., when using power tools on an adjacent structure), which could generate instability or overturning of the tower.
 - Maximum distance between platforms is 2.25m, maximum distance to the first platform is 3.4m.
 - Maximum horizontal force 20kgs.
 - Mobile access and working towers are not designed to be sheeted
 - The tower height used should be appropriate for the working height, e.g. within 2 meters above the platform
 - User training courses cannot be a substitute for instruction manuals but only complement them.
 - Only the original UTS components specified in the manual shall be used.
 - Mobile access and working towers designed in accordance with BS EN 1004-1:2020 are not anchor points for personal fall arrest equipment.
 - Working is only permitted on a platform with a complete side protection including guardrails and toe boards.
 - Mobile access and working towers are not designed to be used as edge protection.

STABILISERS & BALLAST

Stabilisers or outriggers and ballast shall always be fitted when specified. When using the MAT externally stabilisers must be fitted. Should ballast be required, a platform should be positioned on the lowest rung and the weights should be firmly attached to it and evenly distributed. For advice on ballast contact your supplier.

MOVING THE TOWER AND LEAVING IT UNATTENDED

- Adjust the stabilisers to provide ground clearance.
- Unlock the castor wheels.
- Move with manual force only, and only from the base.
- Beware of (overhead) obstructions – live wires, hanging apparatus or other objects.
- Do not move with people or material on the tower.
- Do not move the assembled MAT if wind speeds exceed a moderate breeze.
- When moving the tower over uneven or sloping ground remove all tools.
- Do not move the assembled tower if over 4 meters high.
- Mobile access and working towers shall only be moved on a flat and solid ground without obstacles and not on a slope of more than 10mm/1m
- It is recommended that towers should be tied to a solid structure, when left unattended.
- Recheck that the MAT is vertical or needs readjustment of legs before ascending. (Using spirit level)

LIFTING OF EQUIPMENT

Tools and other equipment should be hauled up by a person on the platform using rope or similar, through the trapdoor of the platform or within the tower footprint.

Please see footprint guide on page 17.

Safe working loads of platform and tower not to be exceeded.

LIFTING OF INDIVIDUAL TOWER COMPONENTS

Raising and lowering components, tools and/or materials by rope should be conducted within the tower base (i.e. within the area bounded by the stabilisers). Ensure that the safe working load of the supporting decks and the tower structure is not exceeded.

Check for environmental changes before every use. (i.e.: all weather conditions)

TIES

When ties are required, they should be in accordance with table 17 of BS 5973:1990 and table 24 of BS 5975:1982. Always tie to a solid structure.

The tie frequency should be at 4 meter intervals or less vertically.

CHECK LIST, INSPECTION CARE AND MAINTENANCE FOR MOBILE ACCESS TOWERS

- All components should be inspected before use to ensure that they are not damaged or broken, particularly the welds.
- ANY damage to ANY part particularly tubular members, castors, platform decking MUST be replaced.
- Adjustable leg threads should be cleaned and lightly oiled.
- All locking claws should be cleaned, and the locking mechanism checked for operation.
- When storing your MAT, please ensure that all components are neatly stored and not left lying around where they could be stood on or damaged.
- When transporting the MAT always tie the components down so that they do not move around and get damaged.
- Should the tower be left unattended it should be tied to a suitable structure and on reuse ALWAYS check that the tower is vertical and safe before ascending correct and complete structure.
- The MAT is not designed to be lifted or suspended as a complete structure.
- Always keep this instruction manual safe.
- Broken, damaged or incorrect components must never be used. The equipment shall be quarantined and assessed for replacement repair or destruction.

WIND EFFECTS

Wind	Beaufort Scale 10 Meters above ground	Force	Speed in m.p.h.	Speed in knots
Moderate Breeze	Raises dust and loose paper, small branches move.	4	13–18	11–16
Strong Breeze	Large branches in motion, telegraph wires whistle.	6	25–31	22–27
Gale Force	Walking is difficult, twigs break off trees.	8	39–46	34–40

- Beware of high, gusty, or moderate breeze conditions in exposed areas. It is recommended that in wind speeds over a Moderate Breeze (see Beaufort Scale below) that work on the tower is stopped and reassessed. If the wind becomes a Strong Breeze, (see Beaufort Scale below) the tower should be tied to a rigid structure. If the wind is likely to reach Gale Force (see Beaufort Scale below) or over, work should be
- Beware of tunnelling effect caused by open ended buildings, uncladded buildings and building corners.

FITTING ADJUSTABLE LEGS

Push caster into adjustable leg. Push caster/adjustable leg assemblies into a span frame. Lock casters. Repeat procedure with a ladder frame.

It is recommended that for ease of levelling a gap of 50mm is left between the bottom

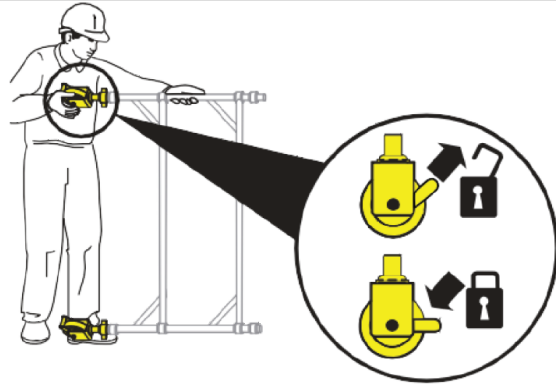

LOCKING CLIPS

Fit the locking clips as shown in the diagram opposite.

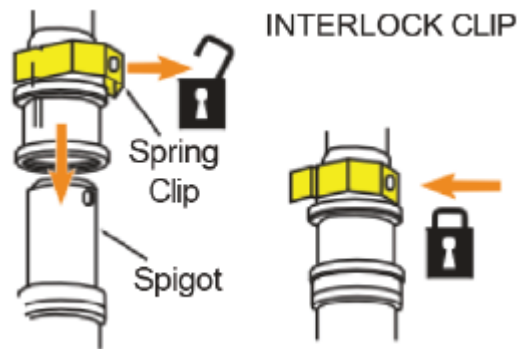

CORRECT FITTING OF HORIZONTAL BRACING

THE CORRECT FITTING OF HORIZONTAL BRACING IS IMPORTANT.

The diagrams opposite illustrate the CORRECT brace positions.

REMEMBER: Always fit braces DOWNWARD or from the inside facing OUTWARD – BUT

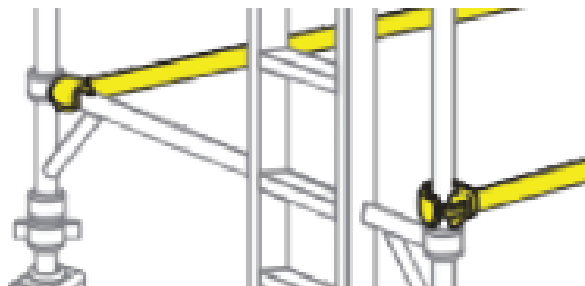

BRACE CLAMP LOCKING

Ensure that the brace clamp is locked as shown.

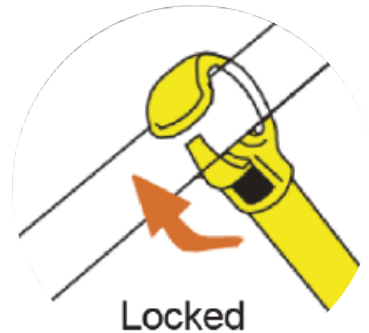

Identifying Components

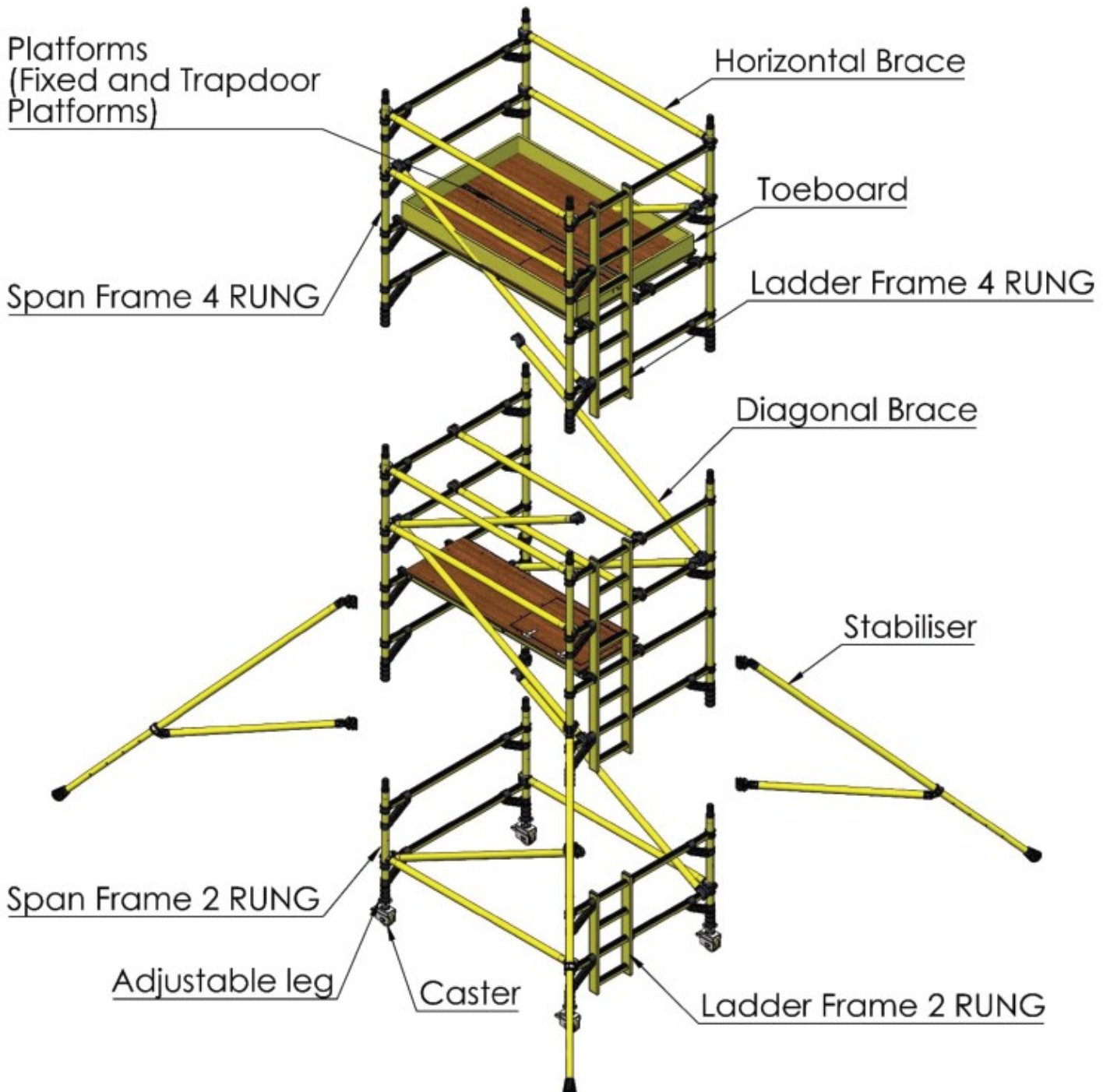

Assembly Procedure: First Frames

UTS recommends that a minimum of two people is required for the assembly of the UTS 500 FRP 1450/850 tower. Only climb the tower from the inside using the ladder section. Always start with the shortest frames at the bottom of the tower

	Platform Heights in Meters	1st Frame	2nd Frame
A)	1.2, 3.2, 5.2, 7.2, 9.2, 11.2	4 Rung	4 Rung
B)	1.7, 3.7, 5.7, 7.7, 9.7, 11.7	2 Rung	3 Rung
C)	2.2, 4.2, 6.2, 8.2, 10.2, 12.2	2 Rung	4 Rung
D)	2.7, 4.7, 6.7, 8.7, 10.7	3 Rung	4 Rung

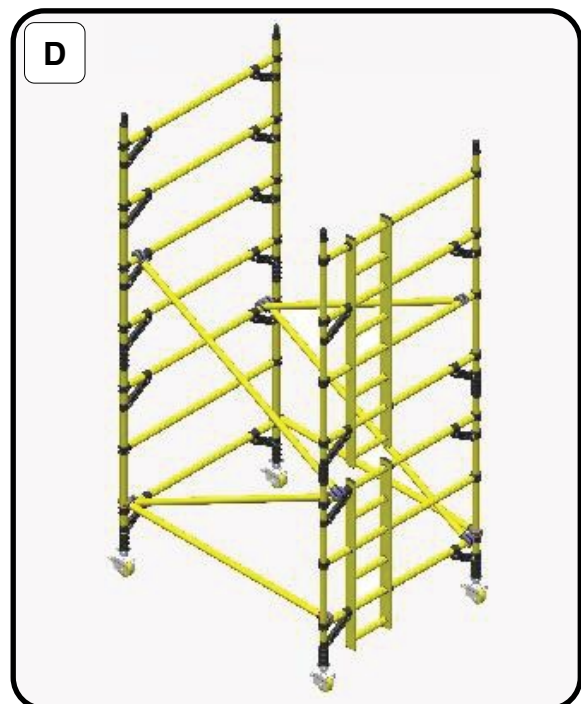
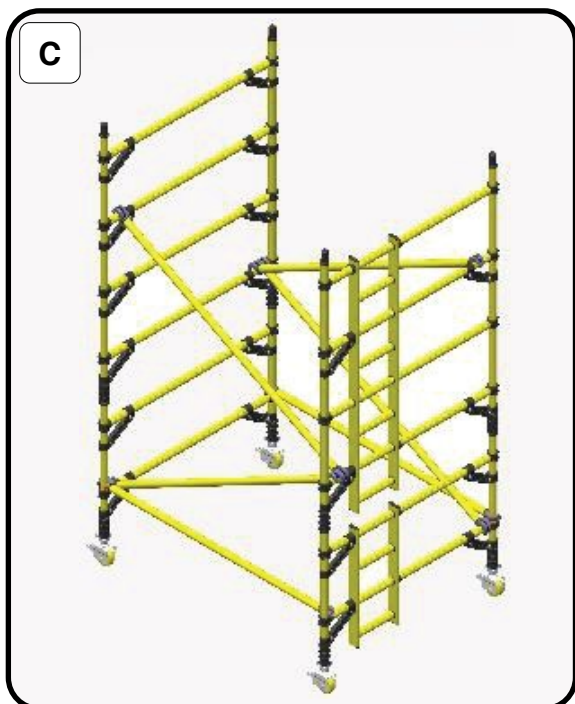
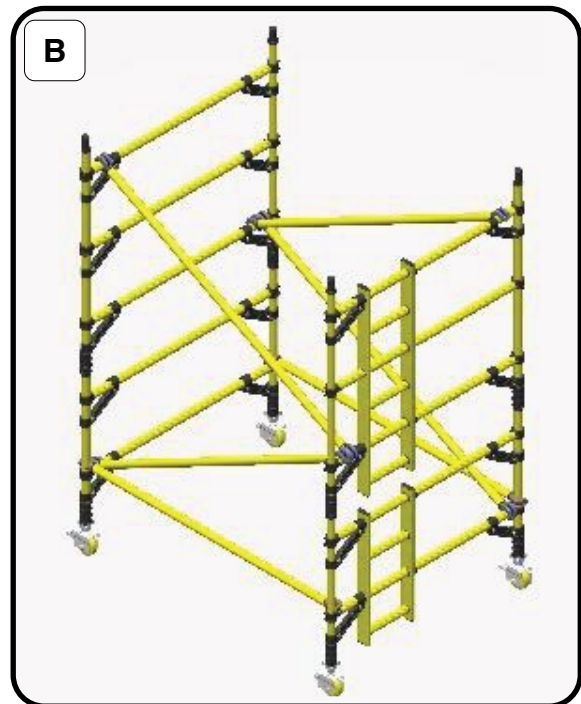
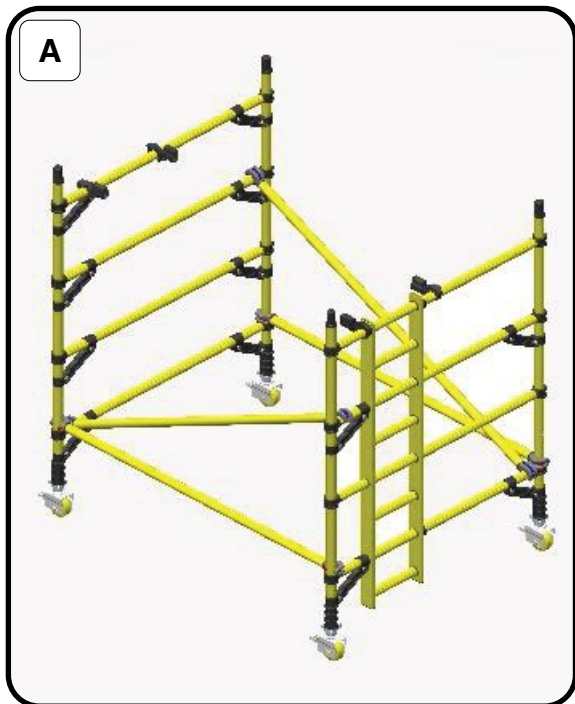

Assembly Procedure: General Assembly

1. Push caster into adjustable leg. Push caster/adjustable leg assemblies into a span frame. Lock casters. Repeat procedure with a ladder frame. It is recommended that for ease of levelling a gap of 50mm is left between the bottom of the leg and the adjustable nut.

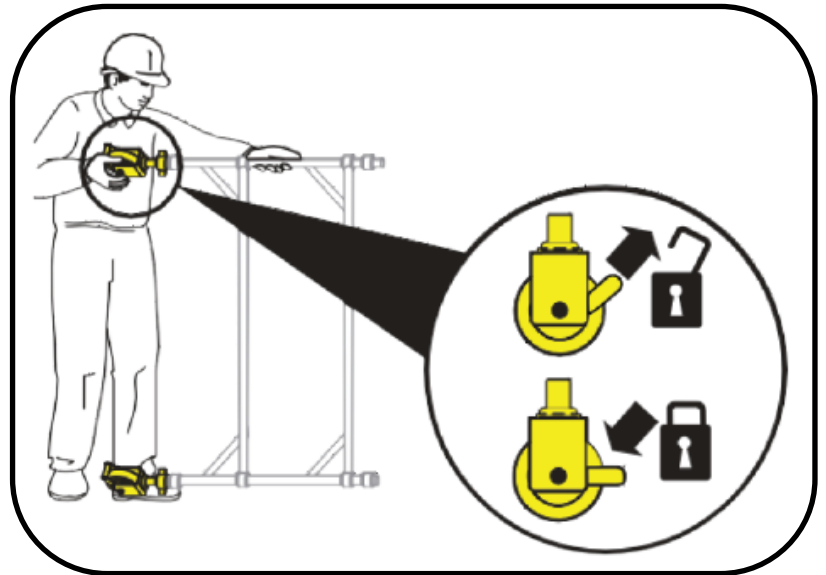

2. Fit one horizontal brace (red) onto the vertical of a span frame, just above the bottom rung, with the claw facing outwards. The frame will now be self-supporting.

All locking claws must be opened before fitting.

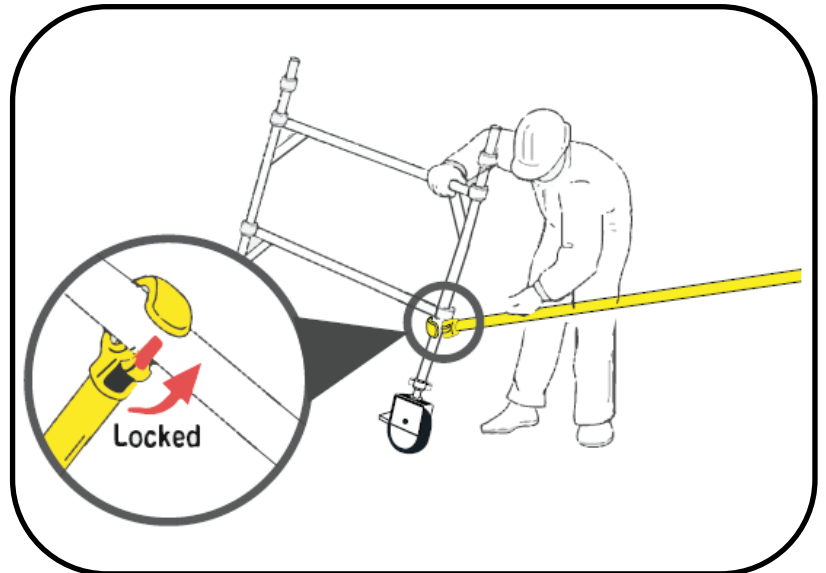

3. Position the ladder frame as shown and fit the other end of the horizontal brace on to the vertical (just above the bottom rung). Fit a second horizontal brace between the bottom rungs on the other side of the frames to square the tower.

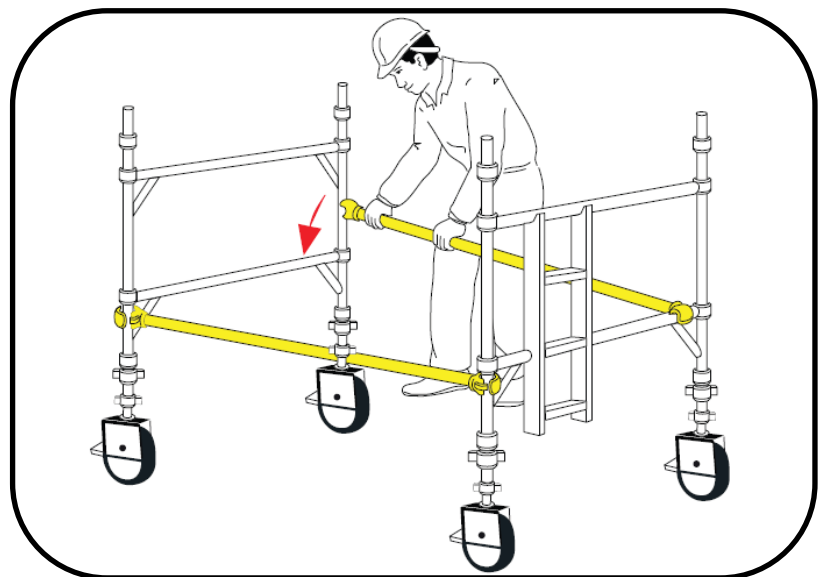

For 1450 Towers turn to page 12
For 850 Towers turn to page 14

Assembly Procedure: 1450 Tower Assembly

Example of a 4.2m platform height
1450 1.8m tower assembly

Fit two additional end frames, ensuring the frame interlock clips are engaged. Ensure ladders and span frames are lined up with previous frames.

Fit two diagonal braces (blue) in opposite directions between the 1st and 3rd rungs.

4. Fit temporary platform to the 1st rung of the tower, to help with levelling.

Ensure the frames are vertical and level by checking with a spirit level and setting the adjustable legs as required.

Only use the adjustment on the legs to level the tower and not to gain extra height.

Fit stabilisers.

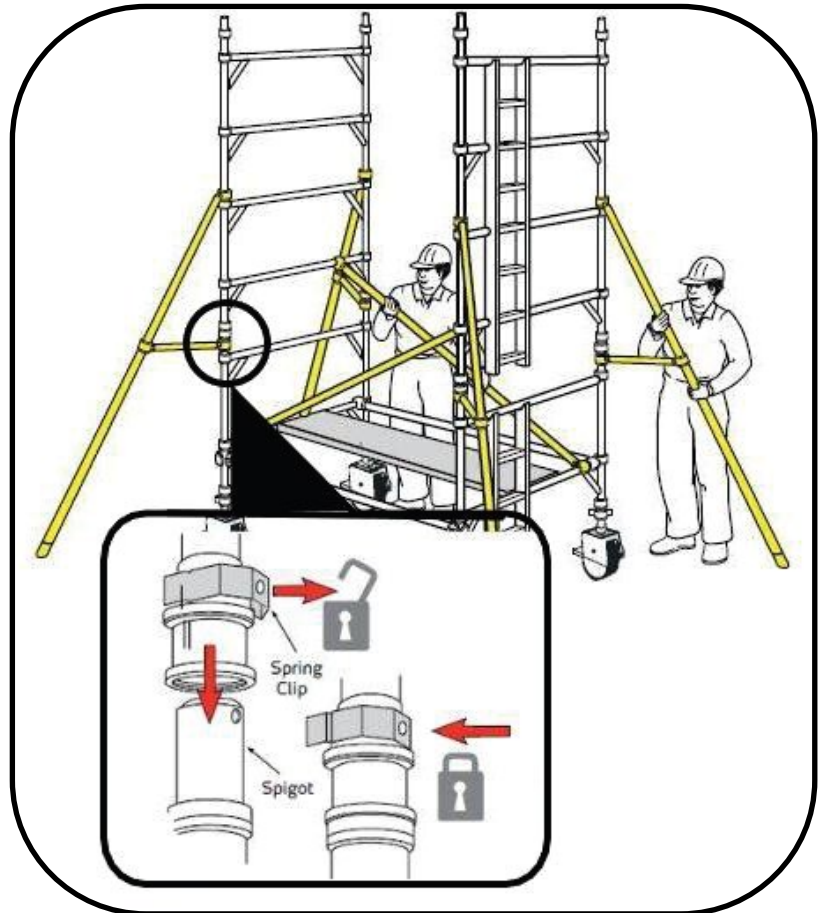

Fit the next pair of diagonal braces in opposite directions between the 3rd and 5th rungs. Fit a trapdoor platform on the 4th rung (2.0m) with the trapdoor next to the ladder. Ensure the trapdoor is positioned with the hinges towards the outside of the tower as shown.

If completing at this height fit a fixed platform alongside it as well.

5. Climb the ladder from the protected trapdoor position, fit the horizontal braces on the 5th and 6th rungs (in that order) on outer edges of the platform(s).

Fit the horizontal braces on both sides of the tower. When horizontal braces are fitted as guardrails, they should be 0.5m and 1.0m (1 and 2 rungs) above the platform.

Do not climb onto the platform until all guardrails are in place.

The temporary platform can be removed and used in the tower after it

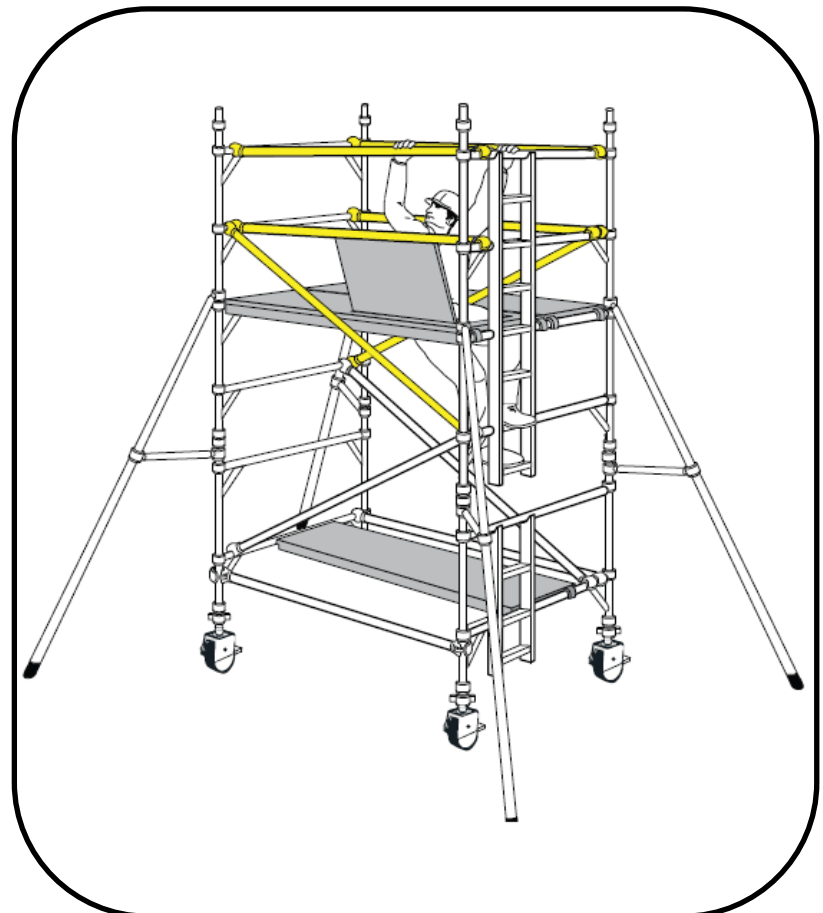

Continue the procedure until the required height is reached, adding additional pairs of end frames, diagonal braces and fitting trapdoor and fixed platforms, as shown on previous steps.

6. At every platform level, add horizontal braces as guardrails from the protected position within the trapdoor (as shown in Step 5).

At the required platform height, fit the fixed platform and a trapdoor platform alongside it. Fit the final guardrails (as shown in Step 5).

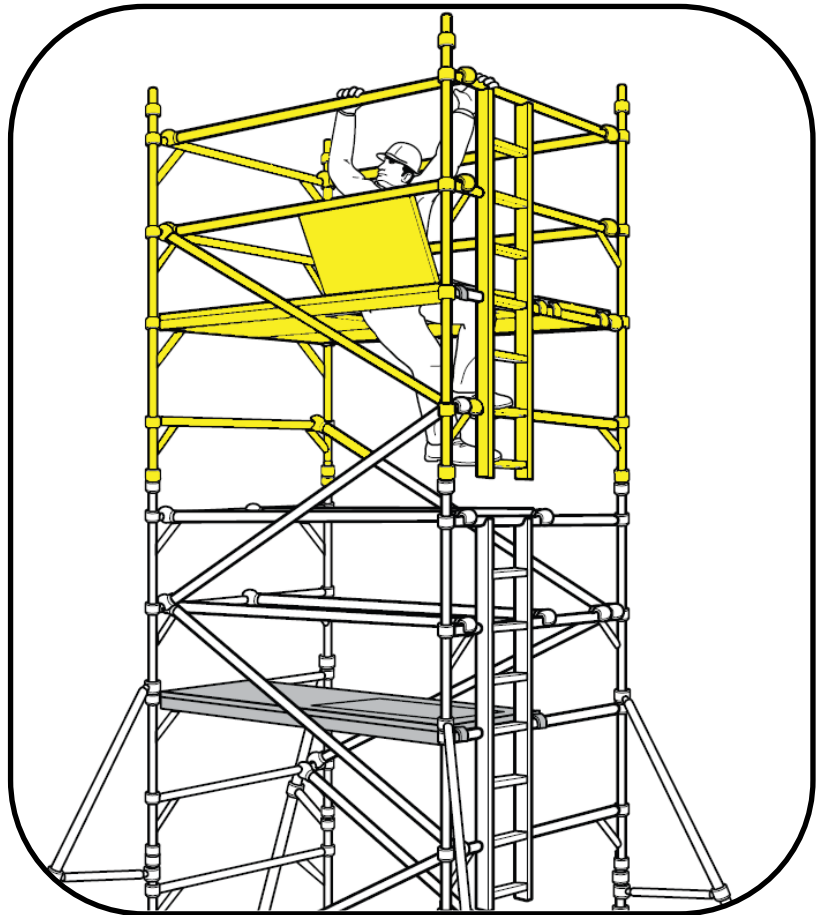

Fit toe boards.

7. **The tower is now complete.**

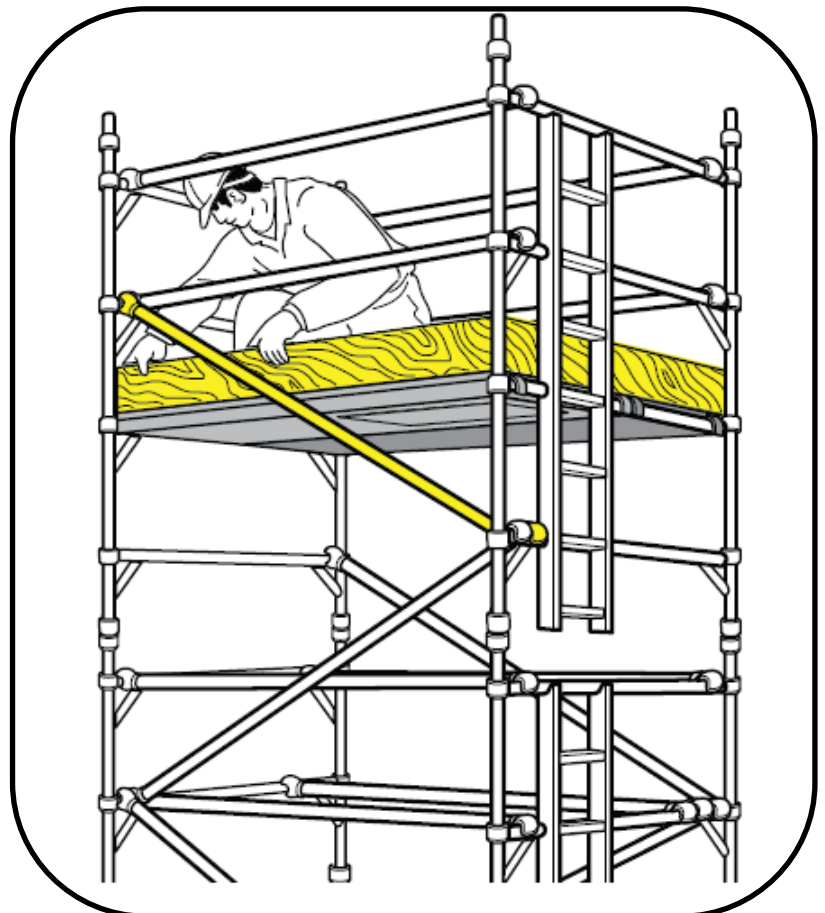

Assembly Procedure: 850 Tower Assembly

Example of a 3.2m platform height 850
1.8m tower assembly

4. Fit a trapdoor platform on the 2nd rung.
Fit the horizontal braces on both sides of the tower. When horizontal braces are fitted as guardrails, they should be 0.5m and 1.0m (1 and 2 rungs) above the platform.

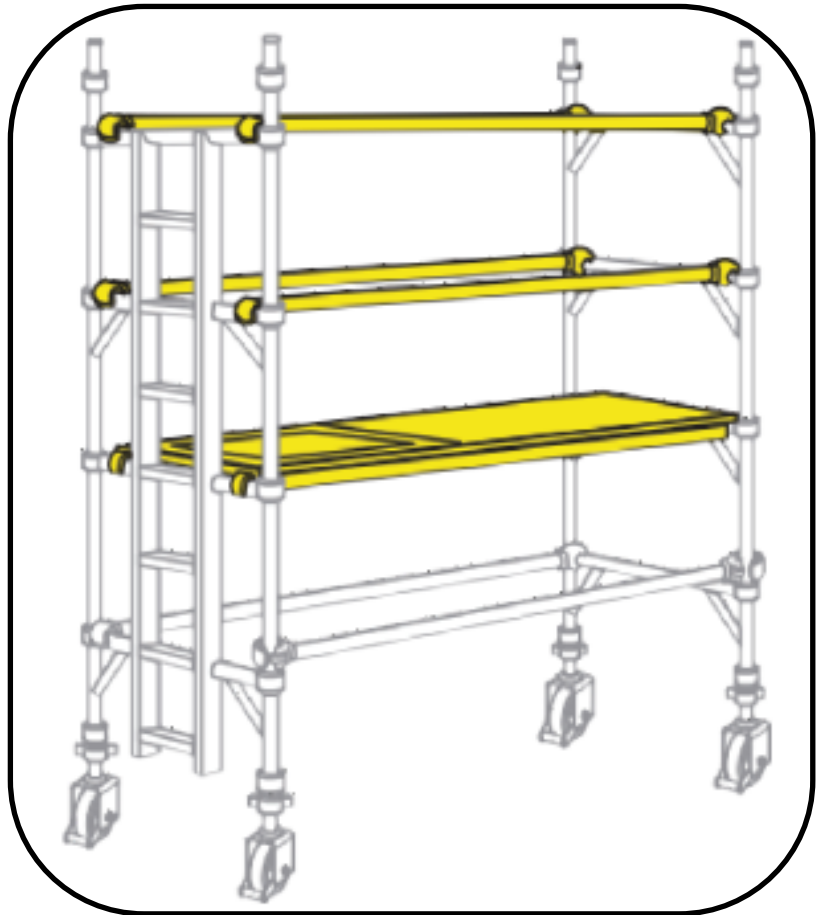

5. Fit two diagonal braces (blue) in opposite directions between the 1st and 3rd rungs.
Ensure the frames are vertical and level by checking with a spirit level and setting the adjustable legs as required.
Only use the adjustment on the legs to level the tower and not to gain extra height.
Fit stabilisers.
Fit two additional end frames, ensuring the frame interlock clips are engaged. Ensure ladders and span frames are lined up with previous frames.

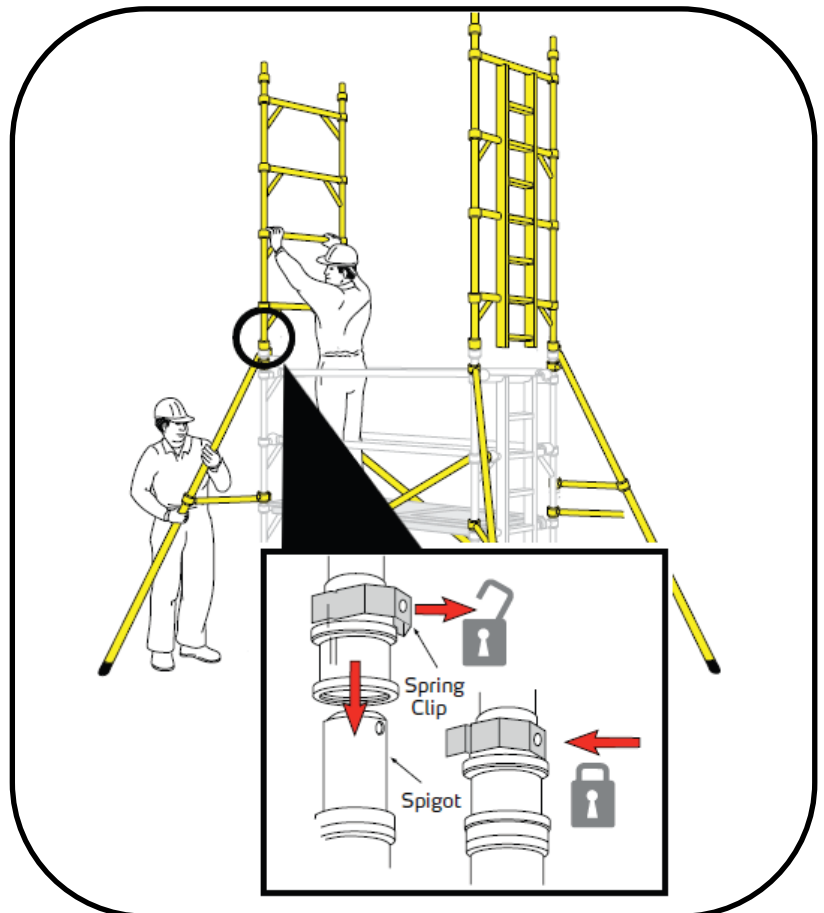

- Fit two pairs of diagonal braces in opposite directions between the 3rd and 5th rungs and the 5th and 7th rungs.
6. Creating a zig zag pattern on opposite sides of the tower.
- Fit a Trap platform 4 rungs (2.0m) above the previous platform.

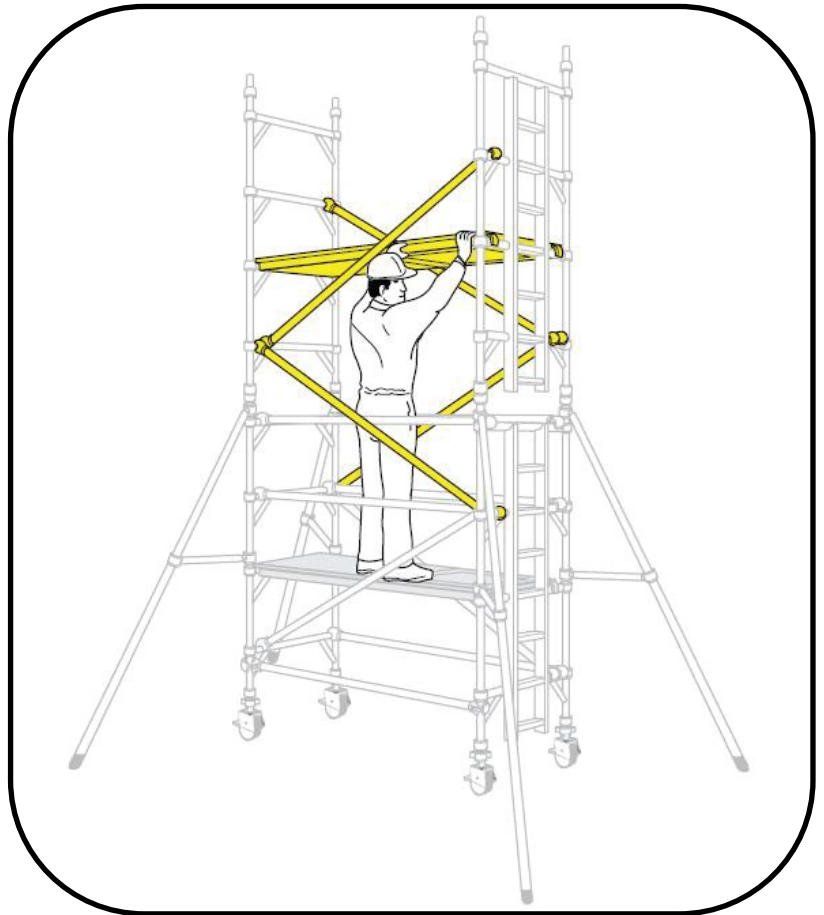

- Climb up the inside of the tower and from protected position of sitting in the trapdoor, fit guardrails to the 7th and 8th rungs (in that order) on both sides of the tower.
7. Fit the horizontal braces on both sides of the tower. When horizontal braces are fitted as guardrails, they should be 0.5m and 1.0m (1 and 2 rungs) above the platform.

Do not climb onto the platform until all guardrail is in place.

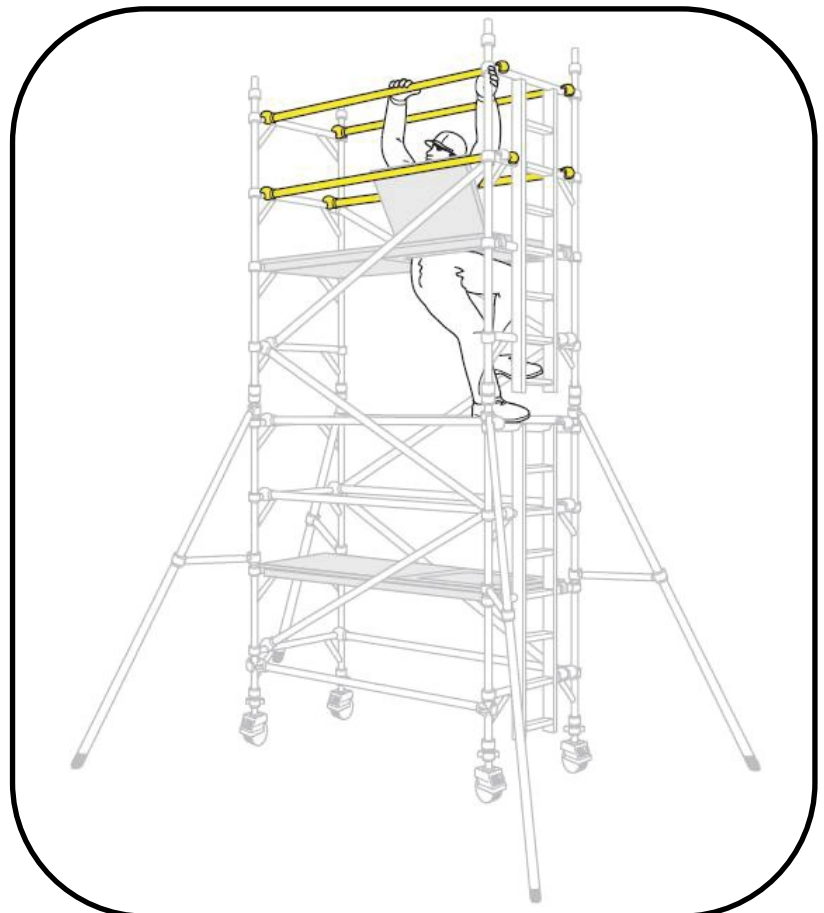

Continue the procedure until the required height is reached, adding additional pairs of end frames, diagonal braces and fitting trapdoor platforms, as shown on previous steps.

8.

At every platform level, add horizontal braces as guardrails from the protected position within the trapdoor (as shown in Step 7).

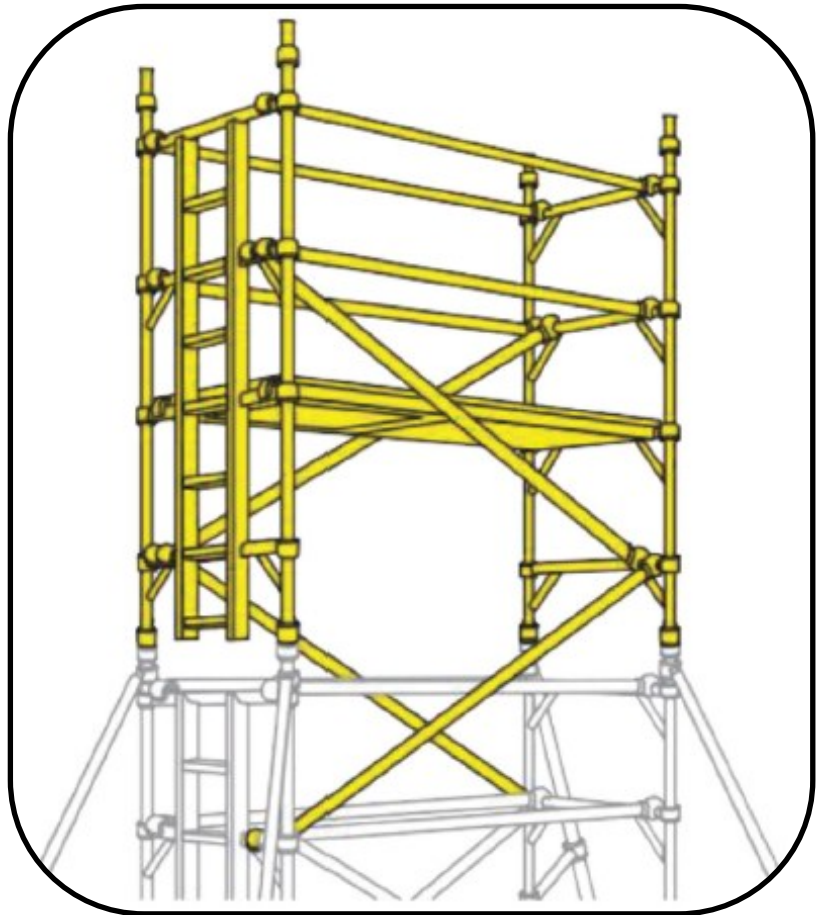

Fit toe boards.

9.

The tower is now complete.

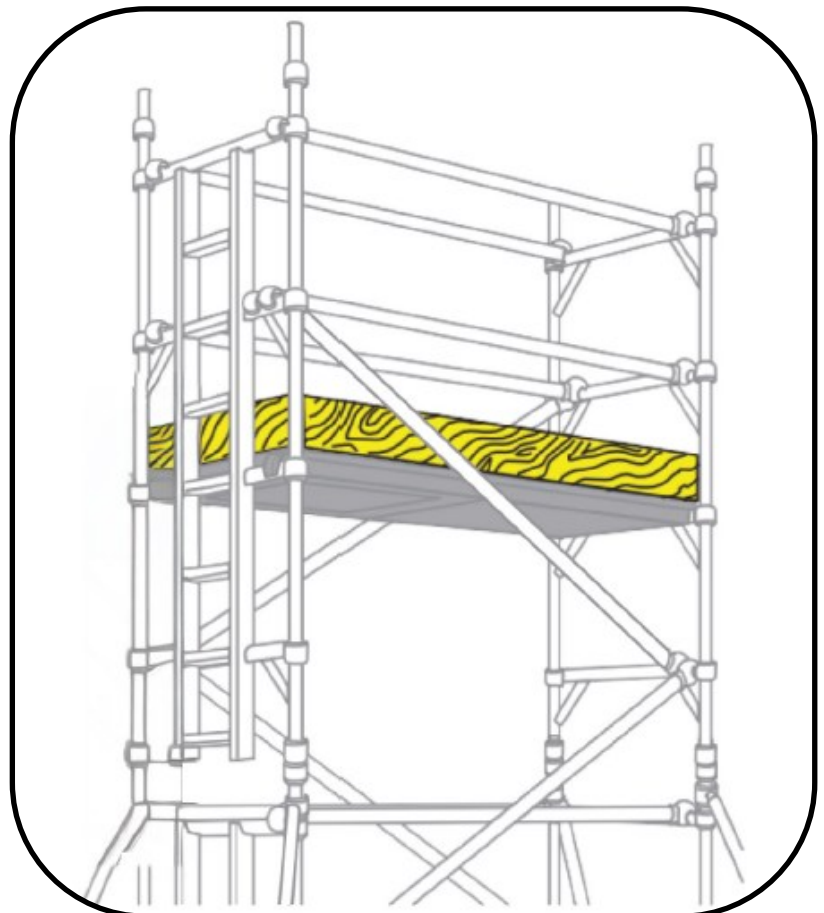

STABILISERS

Attach one stabiliser to each corner of tower at approx. 45 degrees. The bottom arm should be as close to horizontal as possible. Ensure that all four rubber feet are in contact with the ground by adjusting position of the top clamp. Ensure that all clamps are secured. Position stabilisers as shown

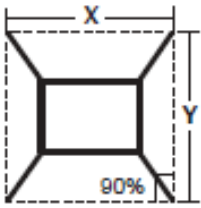

	Double Width 1450 Tower				Single Width 850 Tower			
	1.9m		2.5m		1.9m		2.5m	
	x	y	x	y	x	y	x	y
Small Stabiliser	4330	3868	4918	3868	4330	3268	4918	3268
Large Stabiliser	4998	4536	5586	4536	4082	4629	4650	4650

in the diagrams.

When using telescopic stabilisers, always extend the telescopic legs to their maximum position and lock into position with the interlock clip.

When moving the tower lock each leg just clear of the ground, unlock castors ensuring area is firm and clear of all obstructions both on the ground and above.

After moving check all castors are firmly on the ground and locked, and that the tower is vertical. Re-position stabilisers as above.

When using tower near a wall or in a corner, the stabiliser layout needs to be adjusted to accommodate. As shown in the diagram if against a wall 2 stabilisers should be made parallel to the wall and the

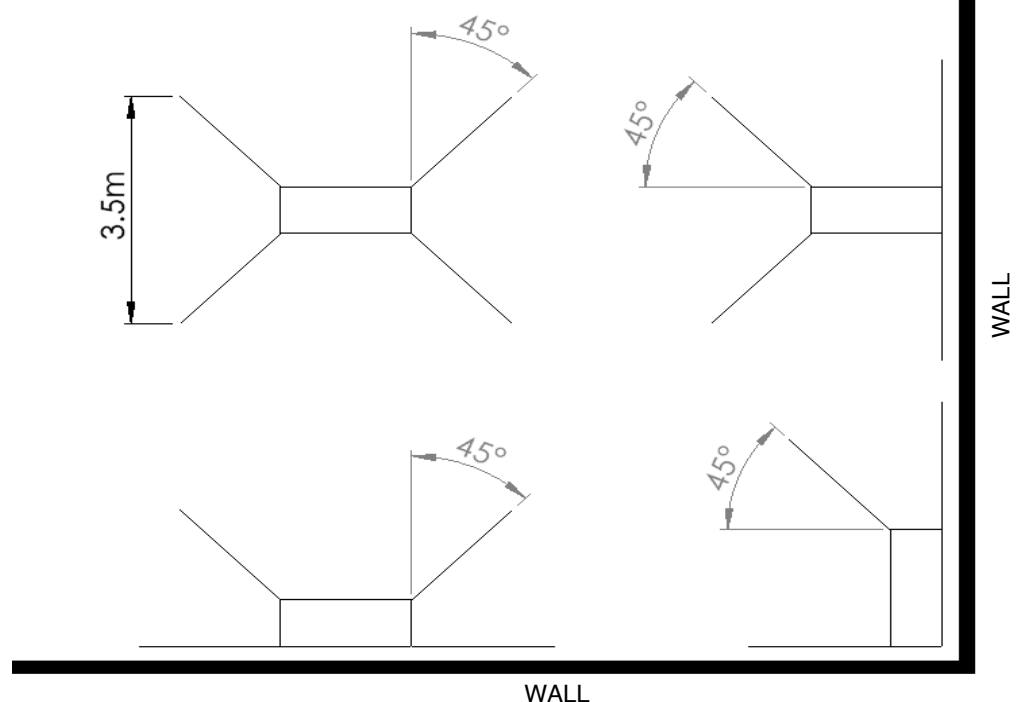

Dismantling

The dismantling procedure should follow the assembly steps in reverse order, take particular attention about the removal of guardrails and platforms.

You should ensure that you are standing in a safe position and always protected by guardrails NEVER remove diagonal braces or stabilisers prematurely.

After removing the toe-boards the operator disengages the horizontal guardrail brace clamps furthest from the trap door, horizontal guardrail braces are then removed with the operator positioned through the trap door before descending to the lower level, from where the upper platform and extensions/guardrail frames can be removed.

NOTES:

DO NOT OVER-REACH and NEVER DROP COMPONENTS when dismantling always lower

Pre-Use checklist

- Check Tower is upright and level using spirit level, to within 0.6°
- All castors are locked and facing in at 45°
- All castors are in contact with the ground
- All frame clips are engaged
- All braces in position
- All platforms guarded by handrails as required
- All brace claws engaged fully and locked on
- All platform securely seated on rungs
- Stabilisers fitted and secured
- Toeboard present on working platform
- Instruction manual available for reference
- Tower is correct height for intended use.
- Check environment before using tower, especially after it has been moved or left unattended.

850 Single Width

Configurations to BSEN 1004:-1:2020

Available in two lengths: 1.8m & 2.5m

Component		Working Height (M)	Internal and External Use																Internal Use Only							
Approx Kgs	Description	Platform Height (M)	3.2	3.7	4.2	4.7	5.2	5.7	6.2	6.7	7.2	7.7	8.8	8.7	9.2	9.7	10.2	10.7	11.2	11.7	12.2	12.7	13.2	13.7	14.2	
3.35	Castors	1.2	4	4	4	4	4	4	4	4	4	4	4	4	4	4	4	4	4	4	4	4	4	4	4	4
1.3	Adjustable Leg Unit	4	4	4	4	4	4	4	4	4	4	4	4	4	4	4	4	4	4	4	4	4	4	4	4	4
7.0	850 x 2 Rung Ladder Frame	1.2	1	1	1	1	1	1	1	1	1	1	1	1	1	1	1	1	1	1	1	1	1	1	1	1
4.3	850 x 2 Rung Span Frame	1	1	1	1	1	1	1	1	1	1	1	1	1	1	1	1	1	1	1	1	1	1	1	1	1
10.4	850 x 3 Rung Ladder Frame	1	1	1	1	1	1	1	1	1	1	1	1	1	1	1	1	1	1	1	1	1	1	1	1	1
5.0	850 x 3 Rung Span Frame	1	1	1	1	1	1	1	1	1	1	1	1	1	1	1	1	1	1	1	1	1	1	1	1	1
13.2	850 x 4 Rung Ladder Frame	1	1	1	1	1	1	2	2	2	3	2	3	3	4	3	4	4	4	5	4	5	5	6	5	6
7.6	850 x 4 Rung Span Frame	1	1	1	1	1	1	2	2	2	3	2	3	3	4	3	4	4	4	5	4	5	5	6	5	6
18.3	1.8m or 2.5m Fixed Platform																									
24.0																										
18.6	1.8m or 2.5m Trap Door	1	1	1	1	2	2	2	2	2	3	3	3	3	4	4	4	4	4	5	5	5	6	6	6	6
25.0	Platform																									
2.0	1.8m or 2.5m Horizontal Brace	6	6	6	6	6	6	10	10	10	14	14	14	14	18	18	18	18	22	22	22	22	26	26	26	26
2.18	2.1m or 2.7m Diagonal Brace	2	3	3	3	4	4	5	6	7	8	9	10	11	12	13	14	15	16	17	18	19	20	21	22	23
2.84	Brace																									
4.7	Small Stabiliser					4	4	4	4	4																
5.5	Large Stabiliser									4	4	4	4	4	4	4	4	4	4	4	4	4	4	4	4	4
9.3	1.8m or 2.5m Folding Toeboard	1	1	1	1	1	1	1	1	1	1	1	1	1	1	1	1	1	1	1	1	1	1	1	1	1
11.4																										
Approx. Tower Shelf weight (Kgs)	Aluminum Folding Toeboard 1.8m	83.7	91.7	97.1	140.8	156.4	164.5	172.1	181.5	215.7	223.8	231.4	237.7	271.8	279.9	287.5	287.5	293.8	328.0	336.0	343.6	349.9	384.1	392.2	399.7	399.7
Approx. Tower Shelf weight (Kgs)	Aluminum Folding Toeboard 2.5m	97.9	106.7	112.1	162.8	182.0	190.7	199.0	209.1	253.3	262.1	270.3	277.2	321.4	330.2	338.4	338.4	345.4	389.6	398.3	406.5	413.5	457.7	466.4	474.7	474.7

Notes:



DOC NO: FRP001, VERSION:1.1, DATE:01/010/25, APPROVED BY:A.GUNTRIPP, REVIEWED BY:M.GRANGER